

Exlar FTX Product Brochure

High-Force Electric Actuator

Specifications

Drawings

Applications

And More...



FTX reduces energy consumption by 60% over hydraulic in milk processing application (above)



FTX
High-Force Electric Actuator

High-Force Universal Actuator

FTX Series

Product Description

The FTX Series high force electric actuators were designed specifically to allow easy migration from hydraulic to electric actuation. They offer up to 15X longer life and twice the force density of common ball screw electric actuators making the roller screw based FTX the right choice when migrating.

Rugged and Reliable

Hydraulic cylinders are commonly installed in harsh industrial settings. All FTX Series models are environmentally sealed to IP65S allowing you to use them in your most challenging applications. In addition, its planetary roller screw mechanism withstands significantly higher shock loads than weaker ball screw alternatives and has better reliability than other electromechanical actuators on the market. Migrate to electric with confidence knowing the FTX Series is every bit as rugged and reliable as the hydraulics they are designed to replace.

Minimal Maintenance

More and more machine builders are looking to eliminate the mess and downtime associated with hydraulic fluid leaks. Electric actuation not only eliminates the problems associated with fluid leaks, it offers significantly higher levels of performance and flexibility than is possible even with servo-hydraulic solutions. FTX Series roller screw actuators allow machine builders to meet ever-increasing performance demands while minimizing or eliminating the maintenance issues associated with traditional hydraulic solutions.

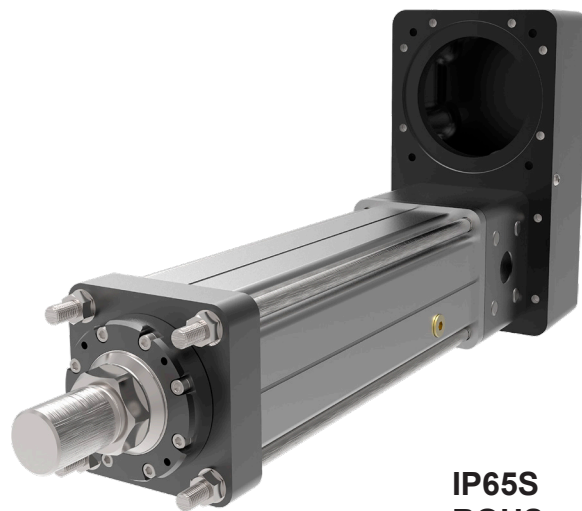

**IP65S
ROHS**

Performance Range				
Model	Frame Size mm (in)	Stroke mm (in)	Max Force kN (lbf)	Max Speed mm/sec (in/sec)
FTX095	95 (3.7)	150 (6), 300 (12), 600 (24), 900 (36), 1200 (48)	22 (5,000)	1500 (59)
FTX125	125 (5.0)		44 (10,000)	1,166 (46)
FTX160	160 (6.3)		89 (20,000)	1000 (39)
FTX215	215 (8.5)		178 (40,000)	875 (34)

Product Features

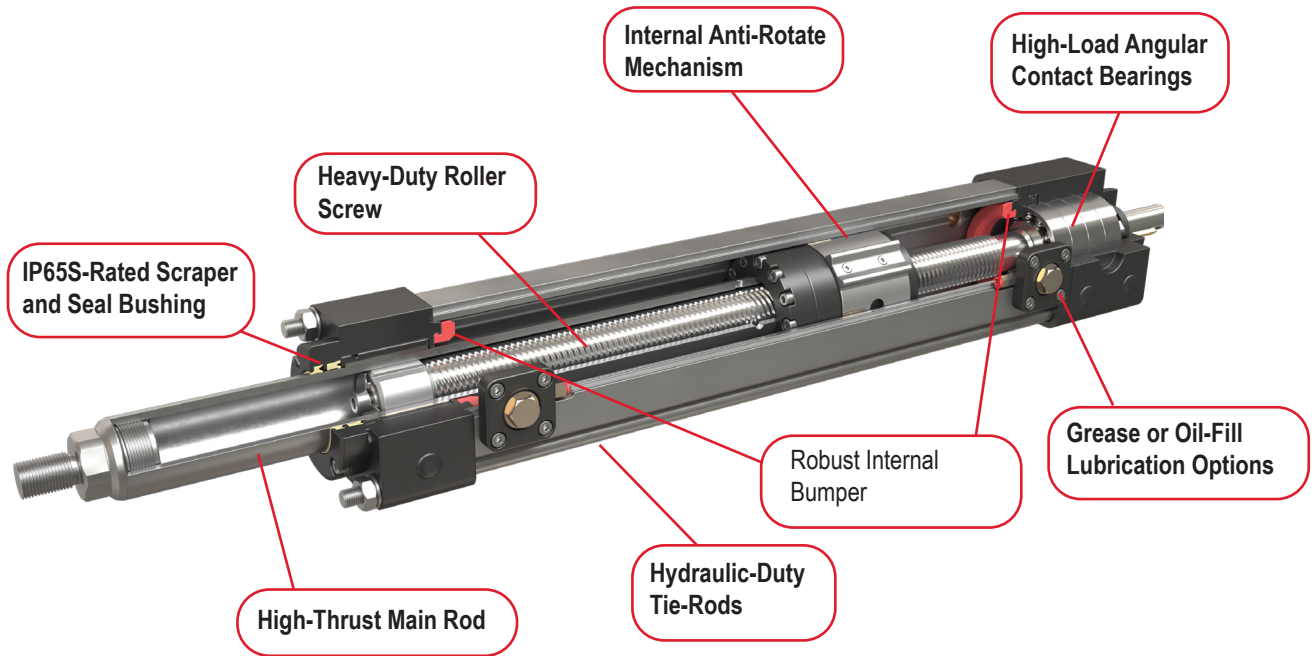

Numerous Configuration Options to Meet Nearly Any Application Requirements!

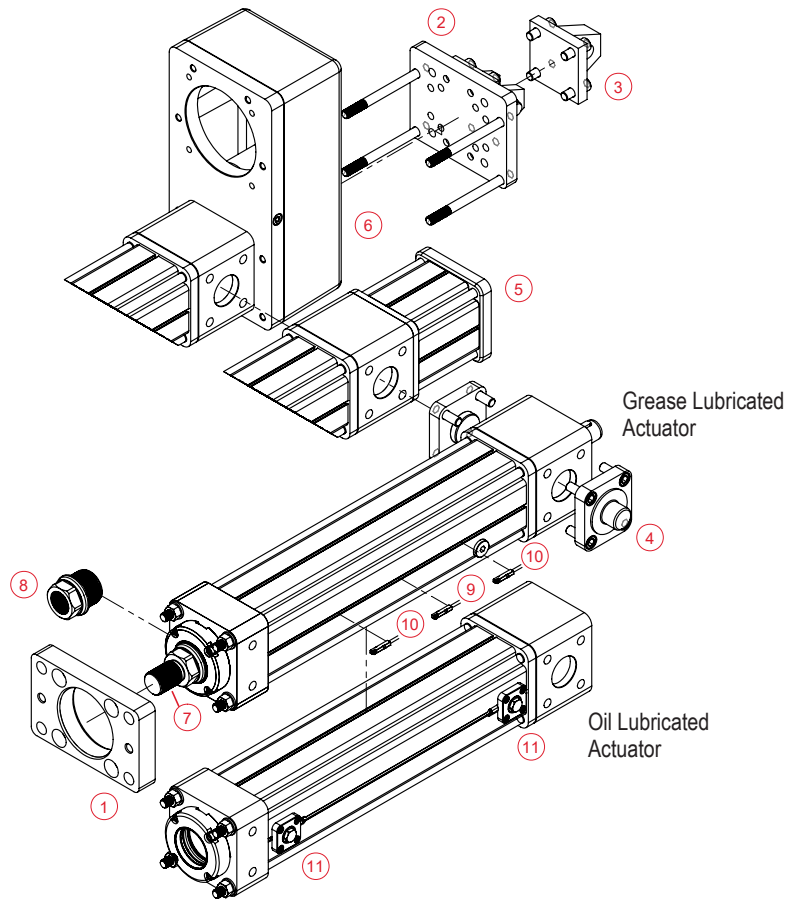

- 1 - Front flange
- 2 - Rear clevis
- 3 - Rear eye
- 4 - Rear trunnion
- 5 - Inline direct drive
- 6 - Parallel, 1:1 belt reduction
Parallel, 2:1 belt reduction
- 7 - Male, metric thread
- 8 - Female, metric thread
- 9 - External limit switch - N.O., PNP or NPN
- 10 - External limit switch - N.C., PNP or NPN
- 11 - Oil ports

Industries & Applications

Successful applications for our FTX Series high force actuators include pressing, forming, and cutting. We have extensive experience in applying the right product and / or system to solve your most difficult manufacturing challenges. Our representatives can provide guidance to optimize system performance, eliminate premature wear, increase production, improve quality, and ultimately reduce costs. Below are some of the most common applications for the FTX Series. Give one of our representatives a call today to go over your application.

Automotive

- Lift station
- Automated assembly
- Riveting / fastening / joining
- Pressing

Entertainment / Simulation

- Action simulators
- Ride automation

Machining

- Automated flexible fixturing
- Machine tooling
- Parts clamping
- Precision grinders
- Forming

Material Handling

- Stamping
- Indexing stages
- Product sorting
- Material cutting
- Web guidance
- Wire winding
- Tube bending

Plastics

- Mold locks
- Part ejecting
- Core pulling
- Gate valve

Process Control

- Conveyor diverters / gates
- Precision valve control
- Tension control

Sawmill / Forestry

- Saw positioning
- Fence positioning

Test

- Test stands

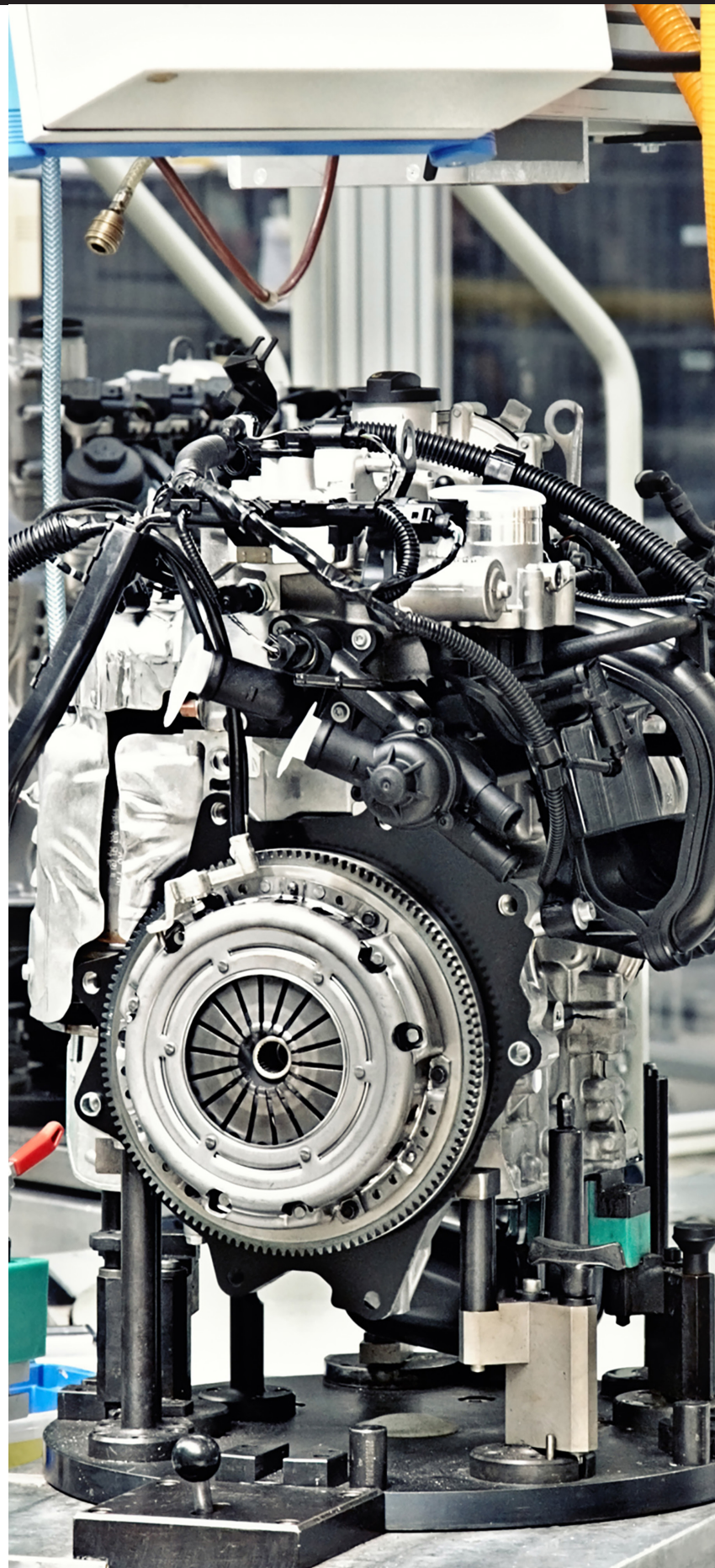



Application Example

Thermoforming OEM Nearly Doubles Production Rate

CUSTOMER

Commodore Technology, a thermoforming machine builder with over 30 years of experience producing a wide variety of customized solutions in the plastics industry was able to nearly double their production rate from 20 cpm to 37 cpm.

APPLICATION

Utilizing two opposing vertical hydraulic cylinders pressing together to compress polystyrene sheets into foam trays at a high rate of speed, they were not able to maintain accurate control or product consistency. Varying wall thicknesses created ribs and contours where there shouldn't be.

CUSTOMER CHALLENGE

In designing their new high capacity thermo-forming machine, the customer required higher forces to press the molds together and a smoother motion profile to minimize vibration. The customer also wanted a "green" solution that eliminated the undesirable traits of hydraulics - such as the mess from hydraulic fluid leaks and constant maintenance.

SOLUTION

As a leader in the manufacturing of roller screw actuators, our FTX Series actuators were chosen over less capable linear motion solutions. They replaced their hydraulic actuator solution with Exlar FTX160 actuators with a high capacity screw, 2:1 parallel mount, oil ports with site gauge and a Schneider servo motor / drive. They are looking to use our GTX80 integrated motor / actuators on future applications.

RESULTS

- Better product consistency
- Nearly doubling the production rate
- Significantly longer life
- Less noise and energy consumption
- Better accuracy and repeatability
- Higher force
- Smoother and more efficient motion
- Millions of cycles without re-lubrication or maintenance

Curtiss-Wright

Exlar

18400 West 77th Street

Chanhassen, MN 55317

Phone: 855-620-6200 (US & Canada)

EXLAR[®]

www.Exlar.com

Exlar[®] is a brand of Curtiss-Wright