

**CURTISS -
WRIGHT**



Exlar[®] GTX Catalog

Integrated Motor Actuator



Table of Contents

Description.....	3	Options	18
Sealed for Long Life with Minimum Maintenance.....	3	Motor Winding / Voltage.....	18
Elevated Ambient Temperature Operation.....	4	Internal Holding Brake	18
Mechanical Specifications	6	Feedback Device Options:.....	18
Exlar GTX060	6	External Anti-rotate Assembly.....	18
Exlar GTX080	6	Splined Rod Option.....	18
Exlar GTX100	7	Stainless Steel Rod Options.....	18
Estimated Service Life	8	Mounting Options.....	18
Service Life Estimate Assumptions:.....	8	External Limit Switch/ Anti-Rotate Assembly	19
Electrical Specifications	9	Dimensions	20
Exlar GTX060	9	Exlar GTX060	20
Exlar GTX080	11	Exlar GTX080	22
Exlar GTX100	12	Exlar GTX100	24
Speed vs. Force Curves	13	Feedback Types for Exlar GTX	27
Exlar GTX060 AC Voltage Winding.....	13	Wiring and Alignment Options	28
Exlar GTX060 DC Voltage Winding	14	Exlar GTX Actuator Ordering Information	41
Exlar GTX080 AC Voltage Winding.....	15	Warranty and Limitations of Liability	42
Exlar GTX080 DC Voltage Winding	16		
Exlar GTX100 AC Voltage Winding.....	17		

Configure and Download Your Model Today!

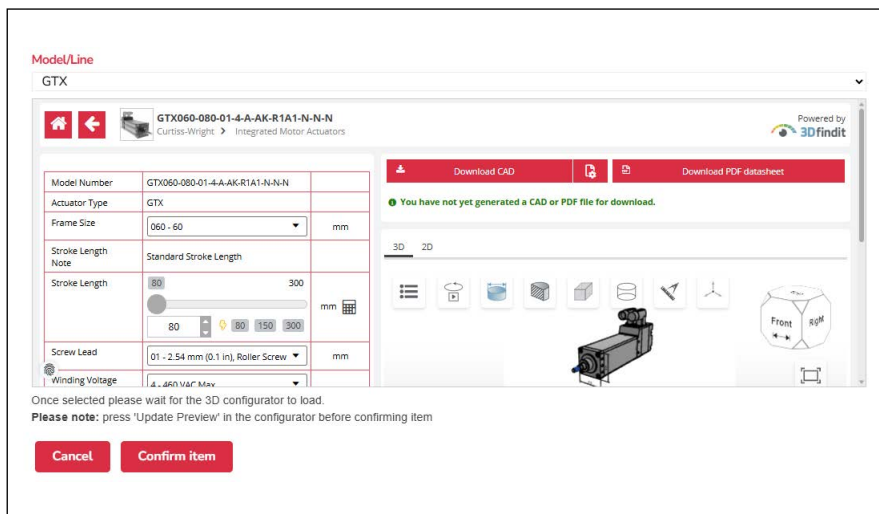



Exlar® GTX

Integrated Motor Actuator

Key Features

- Precise and programmable
- Rugged and reliable
- Powerful and compact
- High quality roller screw for long life

Applications

- Automotive
 - Dispensing, riveting, fastening
- Food and Beverage / Packaging
 - Forming, pick and place, fillers
- Machining
 - Material Cutting, metal forming, stamping
- Medical Equipment
 - Volumetric pumps, patient positioning
- Plastics
 - Die cutters, part ejection, core pull
- Material Handling
 - Tension control, web guidance, wire winding

Description

For applications that require long life and continuous duty, even in harsh environments, the Exlar GTX actuator offers a robust solution. The life of these actuators can exceed that of a ball screw actuator by 15 times, all while delivering high speeds and high forces.

Sealed for Long Life with Minimum Maintenance

Exlar GTX actuators have strong advantages wherever outside contaminants are an issue. In most rotary-to-linear devices, critical mechanisms are exposed to the environment. Thus, these actuators must be frequently inspected, cleaned and lubricated.

In contrast, the converting components in all Exlar GTX units are mounted within sealed motor housing. With a simple bushing and seal on the smooth extending rod, abrasive particles or other contaminants are prevented from reaching the actuator's critical mechanisms. This assures trouble-free operation even in the most harsh environments.

Agency Standards & Approvals		
UL		UL 1004-1
		UL 1004-6
CSA		CSA C22.2 NO. 100
CE	EMC	EN 55014-1
		EN 55014-2
	Safety	IEC/EN 60034-1
	RoHS	RoHS 2011/65/EU and amended with directive 2015/863

Operating Conditions and Usage		
Accuracy:		
Screw Lead Error	µm / 300 mm	25
	in/ft	0.001
Screw Travel Variation	µm / 300 mm	30
	in/ft	0.0012
Screw Backlash	in	0.004
	mm	0.102
Ambient Operating Temperature	°C	0 to 65
	°F	32 to 149
Elevated Ambient Operating Temperature*	°C	-30 to 65
	°F	-22 to 149
Storage Temperature	°C	-80 to 85
	°F	-112 to 185
Friction Torque (typical)	Frame Size (Nm)	060 (0.12)
		080 (0.23)
		100 (0.34)
IP Rating	IP66S	
Vibration**	3.5 grms; 5 to 520 hz	

* Consult cha_applications@curtisswright.com for extended temperature operations

**Resolver feedback

Elevated Ambient Temperature Operation

The speed/torque curves are based on 25 °C ambient conditions. The actuators may be operated at ambient temperatures up to 65 °C.

Elevated Ambient Temp Factor (%) =

$$100\% \times \sqrt{\frac{\text{Max Rated Temp } [\sim 130 \text{ } ^\circ\text{C}] - \text{Environment Temp } [\text{in } ^\circ\text{C}]}{\text{Max Rated Temp } [\sim 130 \text{ } ^\circ\text{C}] - \text{Rated Ambient } [\sim 25 \text{ } ^\circ\text{C}]}} =$$

$100\% \times \sqrt{\frac{130 \text{ } ^\circ\text{C} - \text{Environment Temp}}{105 \text{ } ^\circ\text{C}}}$	= % of published continuous @ 25 °C
---	-------------------------------------

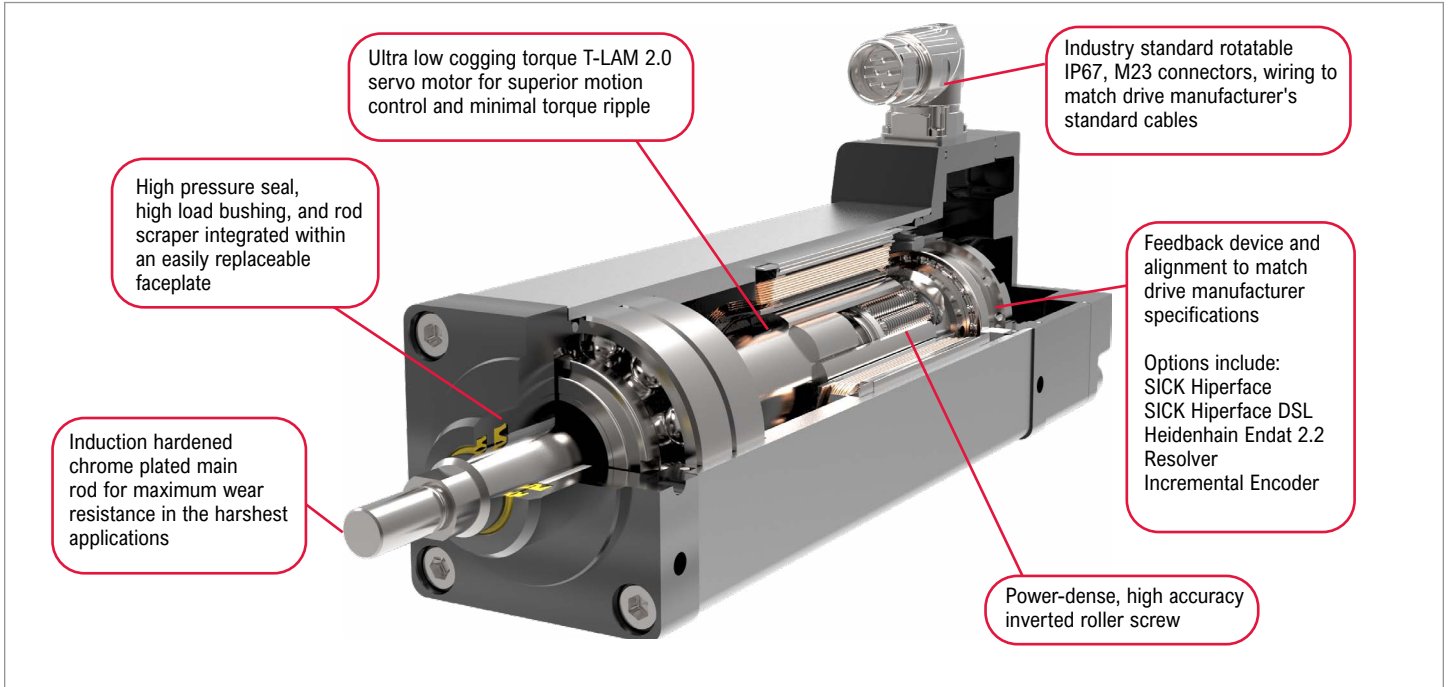

Figure 1: Product Features

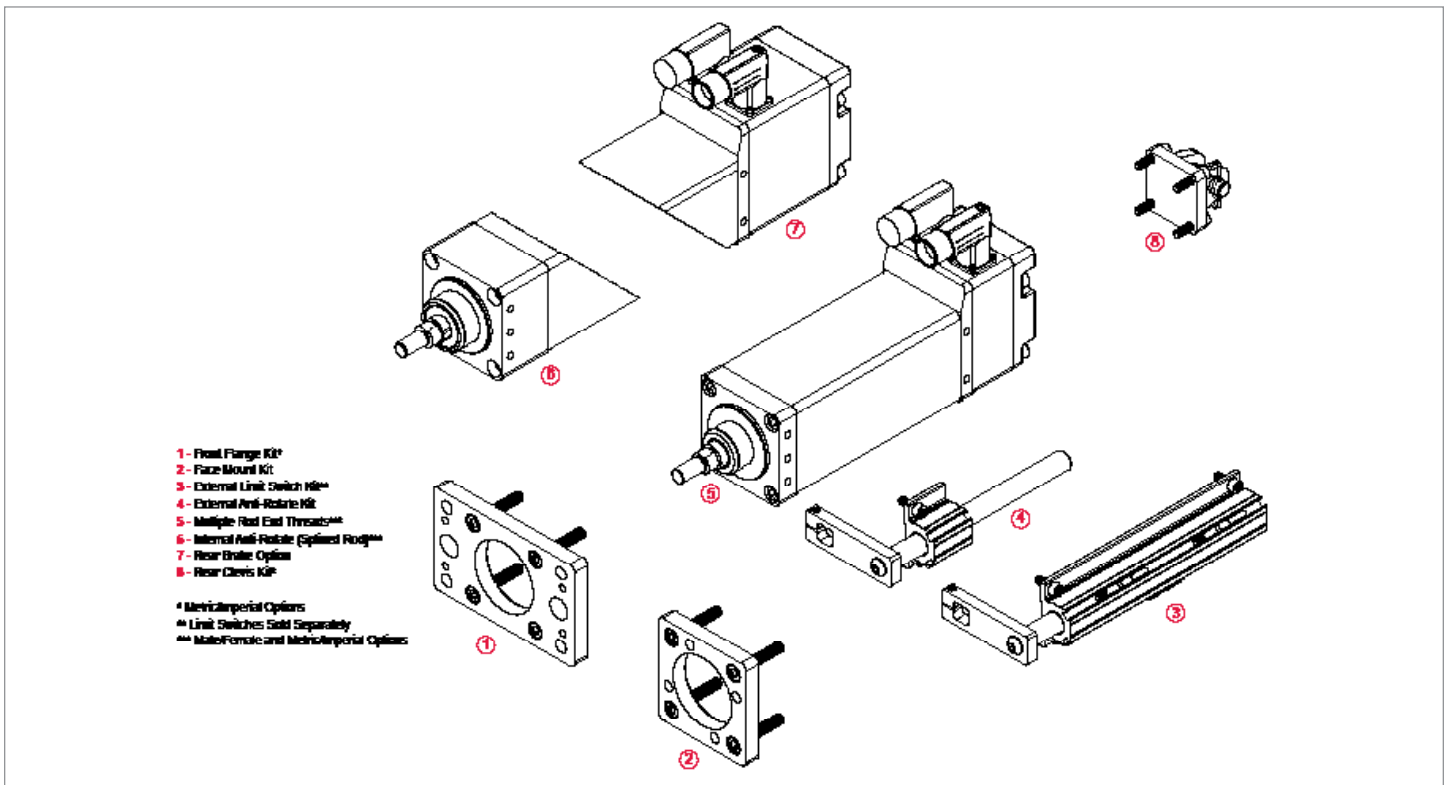

Figure 2: Exploded View

Mechanical Specifications

Exlar GTX060

	Stroke Length mm (in)	Screw Lead mm (in)	Continuous Force Rating N (lbf)		Max Velocity mm/s (in/s)		Dynamic Load Rating N (lbf)	Armature Inertia kg-m ² (in-lb-s ²)
			4 (Vac)	D (Vdc)	4 (Vac)	D (Vdc)		
GTX060-080-01	80 (3.2)	2.54 (0.1)	2,668 (600)	2,668 (600)	318 (12.5)	212 (8.3)	9,230 (2,075)	0.00007367 (0.000652)
GTX060-080-02		5.08 (0.2)	1,900 (427)	1,610 (392)	635 (25.0)	423 (16.7)	6,850 (1,540)	
GTX060-080-04		10.2 (0.4)	1,006 (226)	852 (192)	1,270 (50.0)	847 (33.3)	5,471 (1,230)	
GTX060-150-01	150 (5.9)	2.54 (0.1)	2,668 (600)	2,668 (600)	318 (12.5)	212 (8.3)	9,230 (2,075)	0.00008689 (0.000769)
GTX060-150-02		5.08 (0.2)	1,900 (427)	1,610 (392)	635 (25.0)	423 (16.7)	6,850 (1,540)	
GTX060-150-04		10.2 (0.4)	1,006 (226)	852 (192)	1,270 (50.0)	847 (33.3)	5,471 (1,230)	
GTX060-300-01	300 (11.8)	2.54 (0.1)	2,668 (600)	2,668 (600)	318 (12.5)	212 (8.3)	9,230 (2,075)	0.00011537 (0.001021)
GTX060-300-02		5.08 (0.2)	1,900 (427)	1,610 (392)	635 (25.0)	423 (16.7)	6,850 (1,540)	
GTX060-300-04		10.2 (0.4)	1,006 (226)	852 (192)	1,270 (50.0)	847 (33.3)	5,471 (1,230)	

Maximum velocities listed at maximum voltages
Configured stroke lengths available in 25 mm increments. Consult Exlar sales representative.

Do not exceed 2X the continuous force rating during operation
Continuous force rating based upon 25 °C ambient conditions

Exlar GTX080

	Stroke Length mm (in)	Screw Lead mm (in)	Continuous Force Rating N (lbf)		Max Velocity mm/s (in/s)		Dynamic Load Rating N (lbf)	Armature Inertia kg-m ² (in-lb-s ²)
			4 (Vac)	D (Vdc)	4 (Vac)	D (Vdc)		
GTX080-100-01	100 (3.9)	2.54 (0.1)	8,365 (1,881)	7,101 (1,596)	254 (10.0)	102 (4.0)	24,535 (5,516)	0.000340 (0.003013)
GTX080-100-02		5.08 (0.2)	4,740 (1,066)	4,024 (905)	508 (20.0)	203 (8.0)	25,798 (5,800)	
GTX080-100-05		12.7 (0.5)	2,008 (451)	1,704 (383)	1,270 (50.0)	508 (20.0)	21,795 (4,900)	
GTX080-150-01	150 (5.9)	2.54 (0.1)	8,365 (1,881)	7,101 (1,596)	254 (10.0)	102 (4.0)	24,535 (5,516)	0.000369 (0.003267)
GTX080-150-02		5.08 (0.2)	4,740 (1,066)	4,024 (905)	508 (20.0)	203 (8.0)	25,798 (5,800)	
GTX080-150-05		12.7 (0.5)	2,008 (451)	1,704 (383)	1,270 (50.0)	508 (20.0)	21,795 (4,900)	
GTX080-300-01	300 (11.8)	2.54 (0.1)	8,365 (1,881)	7,101 (1,596)	254 (10.0)	102 (4.0)	24,535 (5,516)	0.000455 (0.004029)
GTX080-300-02		5.08 (0.2)	4,740 (1,066)	4,024 (905)	508 (20.0)	203 (8.0)	25,798 (5,800)	
GTX080-300-05		12.7 (0.5)	2,008 (451)	1,704 (383)	1,270 (50.0)	508 (20.0)	21,795 (4,900)	
GTX080-450-01	450 (17.7)	2.54 (0.1)	8,365 (1,881)	7,101 (1,596)	254 (10.0)	102 (4.0)	24,535 (5,516)	0.000541 (0.004790)
GTX080-450-02		5.08 (0.2)	4,740 (1,066)	4,024 (905)	508 (20.0)	203 (8.0)	25,798 (5,800)	
GTX080-450-05		12.7 (0.5)	2,008 (451)	1,704 (383)	1,270 (50.0)	508 (20.0)	21,795 (4,900)	

Maximum velocities listed at maximum voltages
Configured stroke lengths available in 25 mm increments. Consult Exlar sales representative.

Do not exceed 2X the continuous force rating during operation
Continuous force rating based upon 25 °C ambient conditions

Exlar GTX100

	Stroke Length mm (in)	Screw Lead mm (in)	Continuous Force Rating N (lbf)	Max Velocity mm/s (in/s)	Dynamic Load Rating N (lbf)	Armature Inertia kg-m ² (in-lb-s ²)
			4 (Vac)	4 (Vac)		
GTX100-150-01	150 (5.9)	2.54 (0.1)	15,392 (3,460)	191 (7.5)	54,557 (12,266)	0.0014085 (0.012467)
GTX100-150-02		5.08 (0.2)	12,098 (2,720)	381 (15.0)	55,972 (12,584)	
GTX100-150-05		12.7 (0.5)	5,444 (1,224)	953 (37.5)	37,141 (8,350)	
GTX100-300-01	300 (11.8)	2.54 (0.1)	15,392 (3,460)	191 (7.5)	54,557 (12,266)	0.0017399 (0.015399)
GTX100-300-02		5.08 (0.2)	12,098 (2,720)	381 (15.0)	55,972 (12,584)	
GTX100-300-05		12.7 (0.5)	5,444 (1,224)	953 (37.5)	37,141 (8,350)	

Maximum velocities listed at maximum voltages
 Configured stroke lengths available in 25 mm increments. Consult Exlar sales representative.

Do not exceed 2X the continuous force rating during operation
 Continuous force rating based upon 25 °C ambient conditions

Estimated Service Life

Exlar GTX060

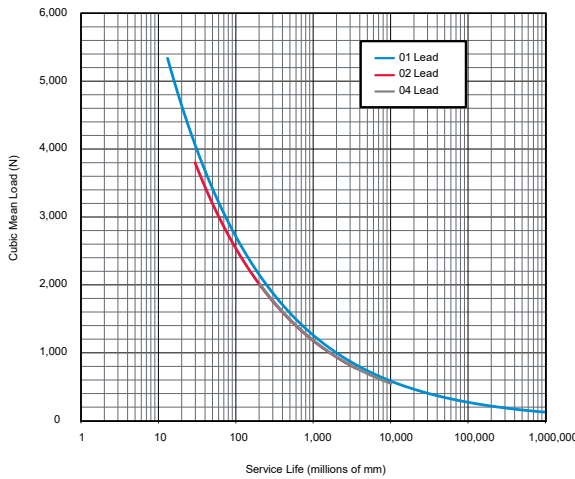

Exlar GTX080

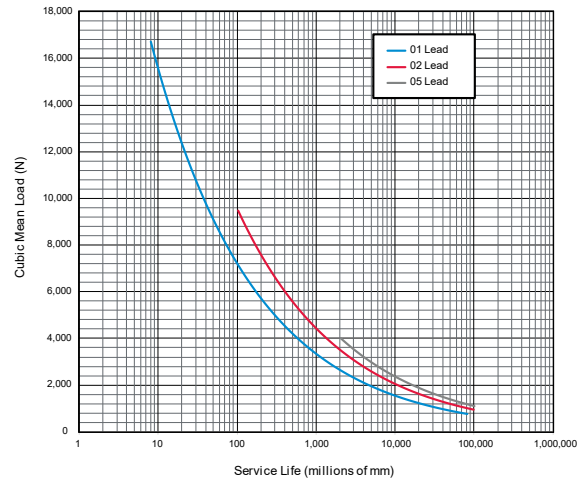

GTX100

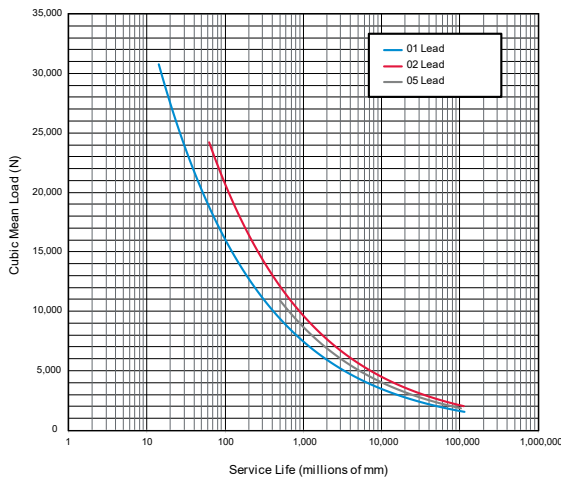

Service Life Estimate Assumptions:

- Sufficient quality and quantity of lubrication is maintained throughout service life.
- No mechanical hard stops (external or internal) or impact loads
- No external side loads
- Does not apply to short stroke, high frequency applications such as fatigue testing or short stroke, high force applications such as pressing. If your application requires high force over a stroke length shorter than the length of the rollers/ nut, please contact Exlar for additional details on calculating estimated service life. You may also download the article "Calculating Life Expectancy" at www.actuation.curtisswright.com.

The L_{10} expected life of a roller screw linear actuator is expressed as the linear travel distance that 90% of properly maintained roller screws manufactured are expected to meet or exceed. This is not a guarantee and these charts should be used for estimation purposes only. For additional details on calculating estimated service life, please refer www.actuation.curtisswright.com.

The underlying formula that defines this value is below. Travel life in millions of inches, where:

C_a = Dynamic load rating (lbf)
 F_{cml} = Cubic mean applied load (lbf)
 l = Roller screw lead (inches)

$$L_{10} = \left(\frac{C_a}{F_{cml}} \right)^3 \times l$$

Electrical Specifications

Exlar GTX060

Motor Voltage		4 (AC)			D (DC)		
Max Bus Voltage		230/460 Vac			24/48 Vdc		
Speed @ Bus Voltage	rpm	5000/7500			2400/5000		
Actuator Lead	in	0.1	0.2	0.4	0.1	0.2	0.4
RMS Sinusoidal Commutation							
Continuous Motor Torque	Nm	1.35	1.81	1.81	1.35	1.53	1.53
	lbf-in	11.9	16.0	16.0	11.9	13.6	13.6
Continuous Current Rating	A	3.0	4.0	4.0	18.3	20.8	20.8
Peak Current Rating	A	6.0	8.0	8.0	36.7	41.7	41.7
Torque Constant (Kt) (±10% @ 25 °C)	Nm/A	0.5			0.08		
	lbf-in/A	4.5			0.7		
Voltage Constant (Ke) (± 10% @ 25 °C)	V/krpm	30.5			5.0		
0 - Peak Sinusoidal Commutation							
Continuous Motor Torque	Nm	1.35	1.81	1.81	1.35	1.5	1.5
	lbf-in	11.9	16.0	16.0	12.0	13.6	13.6
Continuous Current Rating	A	4.3	5.7	5.7	25.9	29.5	29.5
Peak Current Rating	A	8.5	11.3	11.3	51.9	58.9	58.9
Torque Constant (Kt) (± 10% @ 25 °C)	Nm/A	0.35			0.06		
	lbf-in/A	3.2			0.5		
Voltage Constant (Ke) (± 1% @ 25 °C)	V/krpm	43.1			7.0		
Pole Configuration	Number of Poles	8			8		
Resistance (L-L) (± 5% @ 25 °C)	Ohms	2.8			0.1		
Inductance (L-L)(± 15%)	mH	13.8			0.3		
Electrical Time Constant	ms	4.9			3.1		
Insulation Class		460 Vac Max, 180 °C (Class H)					

Specifications subject to change without notice
 Test data derived using NEMA recommended aluminum heatsink 10" x 10" x 1/4" at 25 °C ambient
 Vac Class winding operational compatible with drive voltages up to 460 Vac
 Vdc Class winding operational compatible with drive voltages up to 48 Vdc
 Rotational speed approximately proportional to drive input voltage

Exlar GTX060 Weights	
Description	kg (lb)
Exlar GTX060-80	3.2 (7.0)
Exlar GTX060-150	3.7 (8.1)
Exlar GTX060-300	4.8 (10.5)
Brake Adder	0.7 (1.4)
Front Flange (1)	0.4 (0.9)
Tapped Face (3)	0.3 (0.5)
Rear Clevis (5)	0.2 (0.5)
Imperial Flange (F)	0.3 (0.7)
Imperial Clevis (C)	0.3 (0.7)
Anti Rotate (80 mm stroke)	0.46 (1.0)
Anti Rotate (150 mm stroke)	0.54 (1.2)
Anti Rotate (300 mm stroke)	0.72 (1.6)
Limit Switch Assembly w/Anti-Rotate (80 mm stroke)	0.67 (1.5)
Limit Switch Assembly w/Anti-Rotate (150 mm stroke)	0.81 (1.8)
Limit Switch Assembly w/Anti-Rotate (300 mm stroke)	1.11 (2.5)

Brake Specifications		
Brake Holding Torque (minimum)	Nm	2.5
	lbf-in	22
Brake Voltage	Vdc	24 (-10%/+6%)
Nominal Brake Current at 24 Vdc	A	0.46
Brake Engage/Disengage Time (typical)	ms	10/25

Exlar GTX080

Motor Voltage		4 (AC)	D (DC)
Max Bus Voltage		230/460 Vac	24/48 Vdc
Speed @ Bus Voltage	rpm	3000/6000	1000/2400
RMS Sinusoidal Commutation			
Continuous Motor Torque	Nm	4.51	3.83
	lbf-in	39.9	33.9
Continuous Current Rating	A	4.9	24.2
Peak Current Rating	A	9.9	48.5
Torque Constant (Kt) (± 10% @ 25 °C)	Nm/A	1.02	0.18
	lbf-in/A	9.0	1.6
Voltage Constant (Ke) (± 10% @ 25 °C)	V/krpm	61.6	10.7
0 - Peak Sinusoidal Commutation			
Continuous Motor Torque	Nm	4.51	3.83
	lbf-in	39.9	33.9
Continuous Current Rating	A	6.6	34.6
Peak Current Rating	A	13.3	69.2
Torque Constant (Kt) (± 10% @ 25 °C)	Nm/A	0.72	0.13
	lbf-in/A	6.4	1.1
Voltage Constant (Ke) (± 10% @ 25 °C)	V/krpm	87.1	15.1
Pole Configuration	Number of Poles	8	8
Resistance (L-L) (± 5% @ 25 °C)	Ohms	2.5	0.1
Inductance (L-L)(±15%)	mH	17.3	0.46
Electrical Time Constant	ms	6.8	6.9
Insulation Class	460 Vac Max, 180 °C (Class H)		

Specifications subject to change without notice
 Test data derived using NEMA recommended aluminum heatsink 10" x 10" x 1/4"
 at 25 °C ambient
 Vac Class winding operational compatible with drive voltages up to 460 Vac
 Vdc Class winding operational compatible with drive voltages up to 48 Vdc
 Rotational speed approximately proportional to drive input voltage

Exlar GTX080 Weights	
Description	kg (lb)
Exlar GTX080-100	6.1 (13.5)
Exlar GTX080-150	6.8 (14.9)
Exlar GTX080-300	8.6 (19.0)
Exlar GTX080-450	10.5 (23.1)
Brake Adder	1.1 (2.5)
Front Flange (1)	1.0 (2.2)
Tapped Face (3)	0.6 (1.2)
Rear Clevis (5)	0.4 (0.8)
Imperial Flange (F)	0.8 (1.8)
Imperial Clevis (C)	0.8 (1.7)
Anti Rotate (100 mm stroke)	0.5 (1.1)
Anti Rotate (150 mm stroke)	0.6 (1.3)
Anti Rotate (300 mm stroke)	0.8 (1.8)
Anti Rotate (450 mm stroke)	1.1 (2.4)
Limit Switch Assembly w/Anti-Rotate (100 mm stroke)	0.9 (1.9)
Limit Switch Assembly w/Anti-Rotate (150 mm stroke)	1.0 (2.3)
Limit Switch Assembly w/Anti-Rotate (300 mm stroke)	1.6 (3.5)
Limit Switch Assembly w/Anti-Rotate (450 mm stroke)	2.1 (4.7)

Brake Specifications		
Brake Holding Torque (minimum)	Nm	4.5
	lbf-in	40
Brake Voltage	Vdc	24 (-10%/+6%)
Nominal Brake Current at 24 Vdc	A	0.5
Brake Engage/Disengage Time (typical)	ms	18/35

Exlar GTX100

Motor Voltage		4 (AC)
Max Bus Voltage		230/460 Vac
Speed @ Bus Voltage	rpm	3000/4500
RMS Sinusoidal Commutation		
Continuous Motor Torque	Nm	12.23
	lbf-in	108.2
Continuous Current Rating*	A	12.3
Peak Current Rating*	A	24.7
Torque Constant (Kt) (± 10% @ 25 °C)	Nm/A	1.11
	lbf-in/A	9.8
Voltage Constant (Ke) (± 10% @ 25 °C)	V/krpm	67.0
0 - Peak Sinusoidal Commutation		
Continuous Motor Torque	Nm	12.23
	lbf-in	108.2
Continuous Current Rating	A	17.4
Peak Current Rating	A	34.8
Torque Constant (Kt) (± 10% @ 25 °C)	Nm/A	0.78
	lbf-in/A	6.92
Voltage Constant (Ke) (± 10% @ 25 °C)	V/krpm	94.8
Pole Configuration	Number of Poles	8
Resistance (L-L) (± 5% @ 25 °C)	Ohms	0.65
Inductance (L-L)(± 15%)	mH	4.9
Electrical Time Constant	ms	7.6
Insulation Class	460 Vac Max, 180 °C (Class H)	

Specifications subject to change without notice
 Test data derived using NEMA recommended aluminum heatsink 12" x 12" x 1/2"
 at 25 °C ambient
 Vac Class winding operational compatible with drive voltages up to 460 Vac
 Rotational speed approximately proportional to drive input voltage

* For actuators with a 0.1" lead, the torque and current must be limited to 8.89 Nm/9.0 A not to exceed the continuous force rating specified in the mechanical specifications table on page 6. Peak torque and current values would be 2x the continuous values

GTX100 Weights	
Description	kg (lb)
Exlar GTX100-150	13.1 (28.8)
Exlar GTX100-300	16.0 (35.2)
Brake Adder	1.2 (2.7)
Front Flange (1)	2.2 (4.7)
Tapped Face (3)	1.1 (2.4)
Rear Clevis (5)	0.8 (1.8)
Imperial Flange (F)	1.9 (4.1)
Imperial Clevis (C)	1.1 (2.5)
Anti Rotate (150 mm stroke)	1.5 (3.2)
Anti Rotate (300 mm stroke)	2.0 (4.5)
Limit Switch Assembly w/Anti-Rotate (150 mm stroke)	2.0 (4.5)
Limit Switch Assembly w/Anti-Rotate (300 mm stroke)	2.8 (6.2)

Brake Specifications		
Brake Holding Torque (minimum)	Nm	11
	lbf-in	97
Brake Voltage	Vdc	24 (-10%/+6%)
Nominal Brake Current at 24 Vdc	A	0.75
Brake Engage/Disengage Time (typical)	ms	25/40

Speed vs. Force Curves

These charts represent typical linear speed versus linear force curves for the Exlar GTX actuators using common brushless motor amplifiers. The Exlar GTX Series are compatible with many different brushless motor amplifiers; any differences in the performance ratings of these amplifiers can alter the actuator's performance. Thus, the curves below should be used for estimation only. (Further information is available by contacting your local sales representative.)

Exlar GTX060 AC Voltage Winding

Exlar GTX060 - 01
2.54 mm (0.1 in) Screw Lead

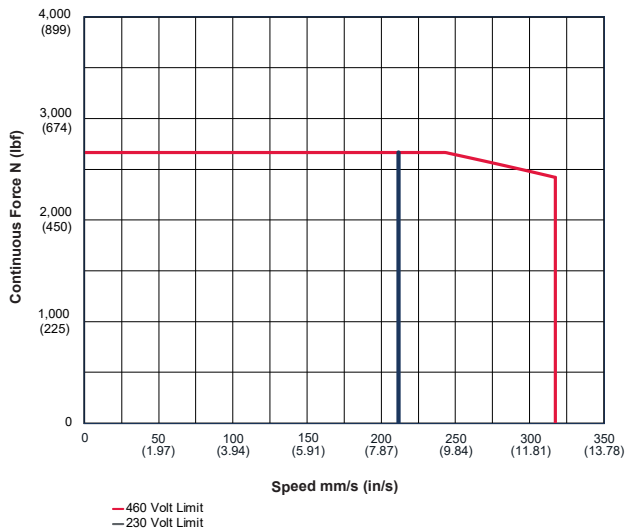

Exlar GTX060 0- 04
10.16 mm (0.4 in) Screw Lead

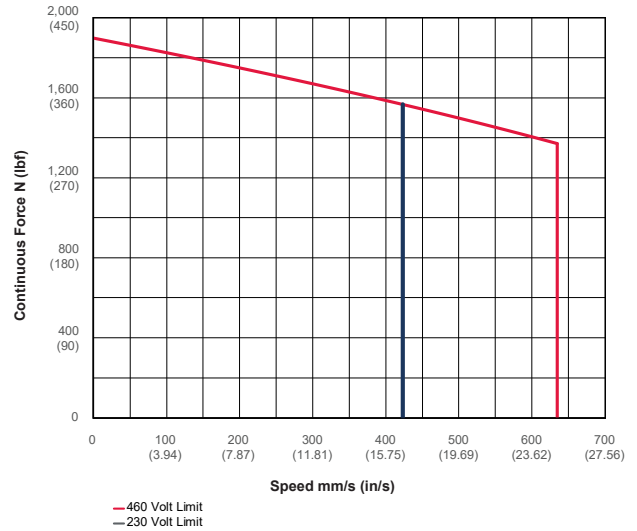

Exlar GTX060 - 02
5.08 mm (0.2 in) Screw Lead

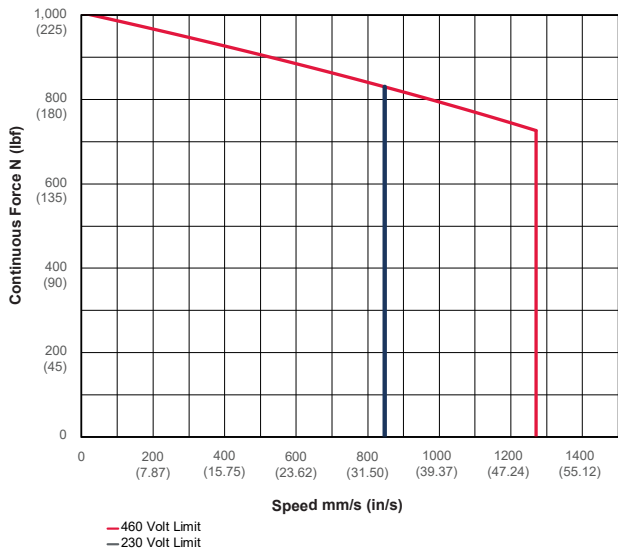

Exlar GTX060 DC Voltage Winding

Exlar GTX060 - 01
2.54 mm (0.1 in) Screw Lead

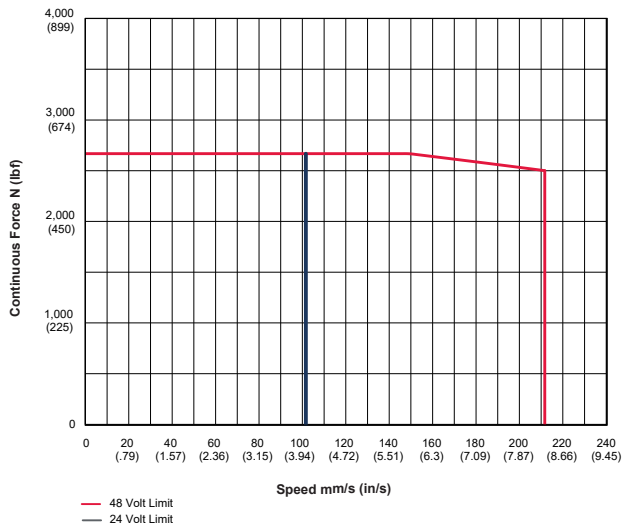

Exlar GTX060 - 04
10.16 mm (0.4 in) Screw Lead

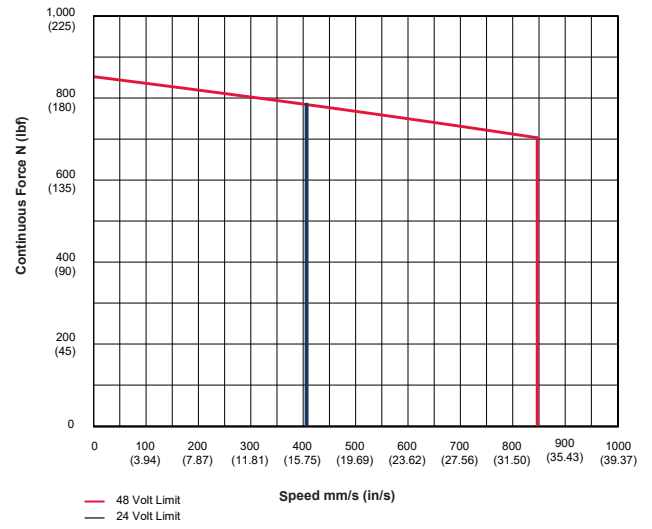

Exlar GTX060 - 02
5.08 mm (0.2 in) Screw Lead

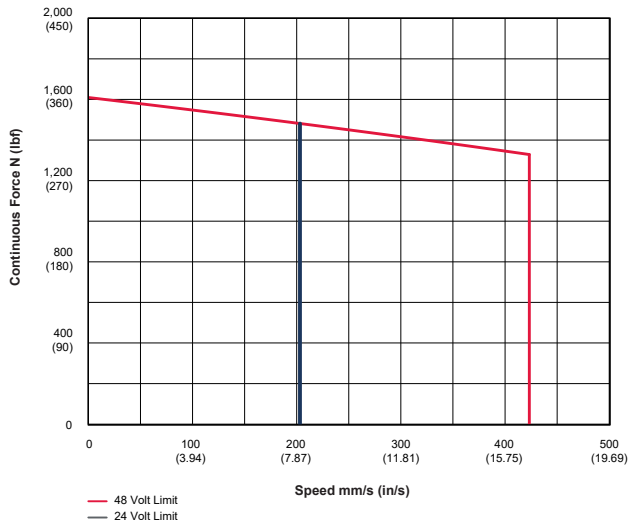

Exlar GTX080 AC Voltage Winding

Exlar GTX080 - 01
2.54 mm (0.1 in) Screw Lead

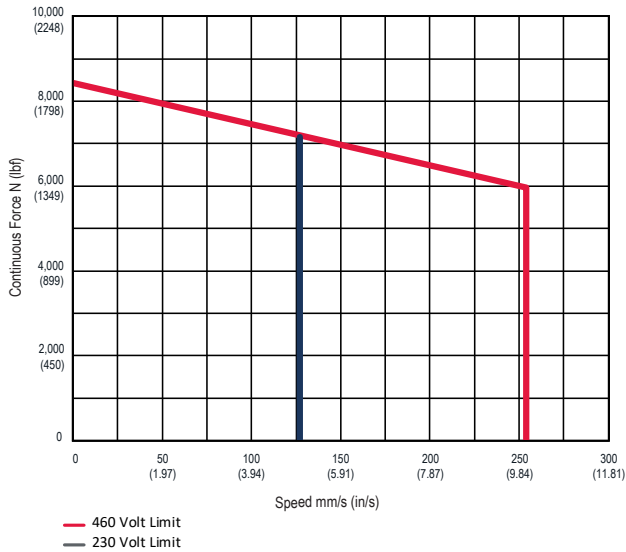

Exlar GTX080 - 05
12.7 mm (0.5 in) Screw Lead

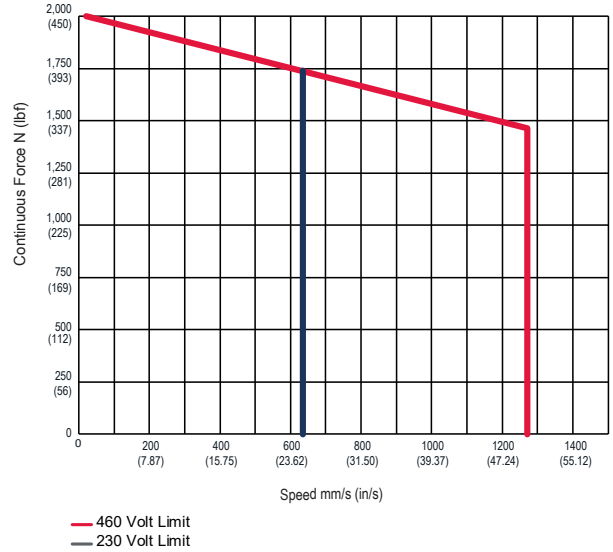

Exlar GTX080 - 02
5.08 mm (0.2 in) Screw Lead

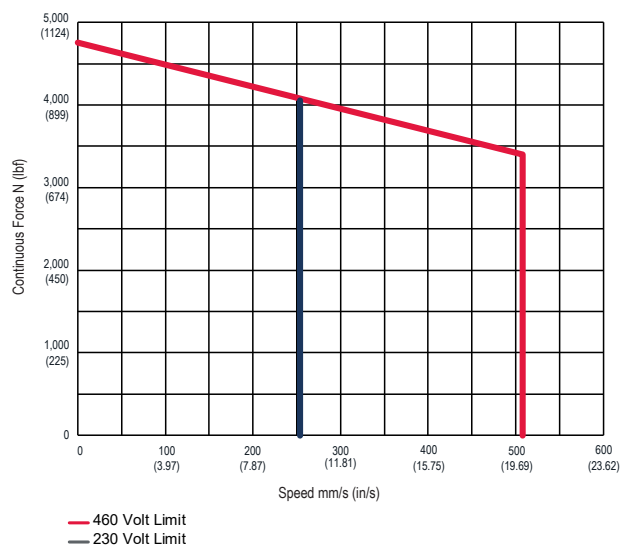

Exlar GTX080 DC Voltage Winding

Exlar GTX080 - 01
2.54 mm (0.1 in) Screw Lead

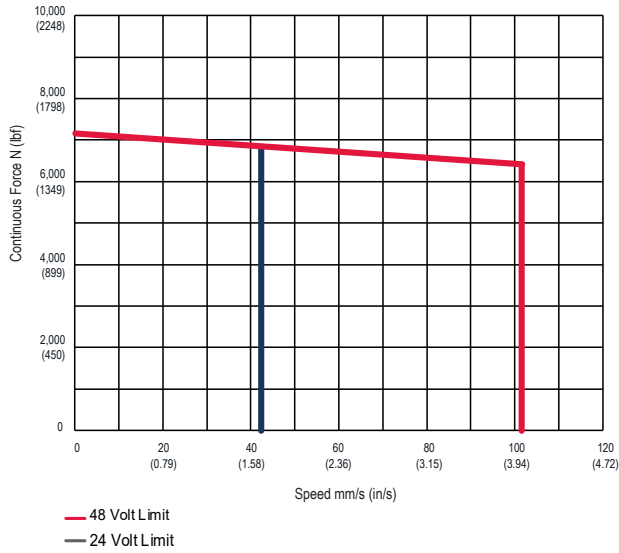

Exlar GTX080 0- 05
12.7 mm (0.5 in) Screw Lead

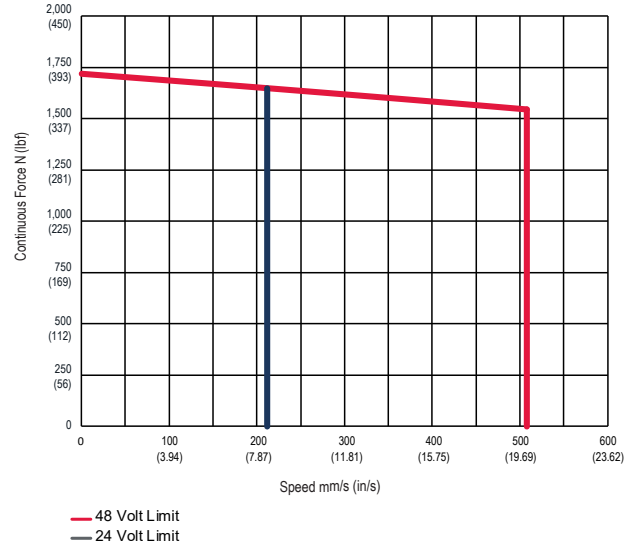

Exlar GTX080 - 02
5.08 mm (0.2 in) Screw Lead

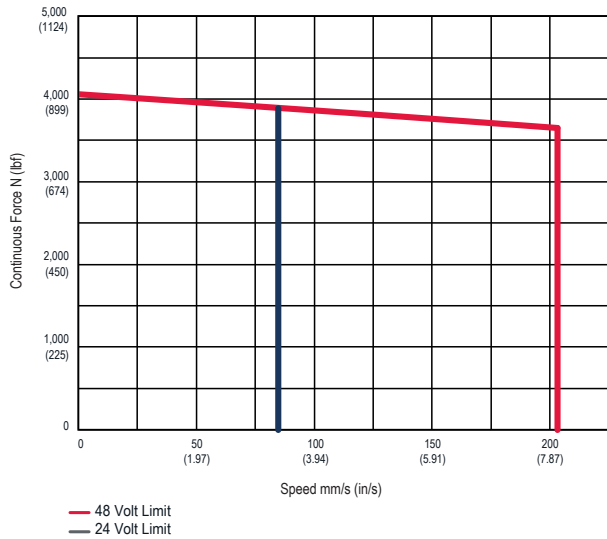

Exlar GTX100 AC Voltage Winding

Exlar GTX100 - 01
2.54 mm (0.1 in) Screw Lead

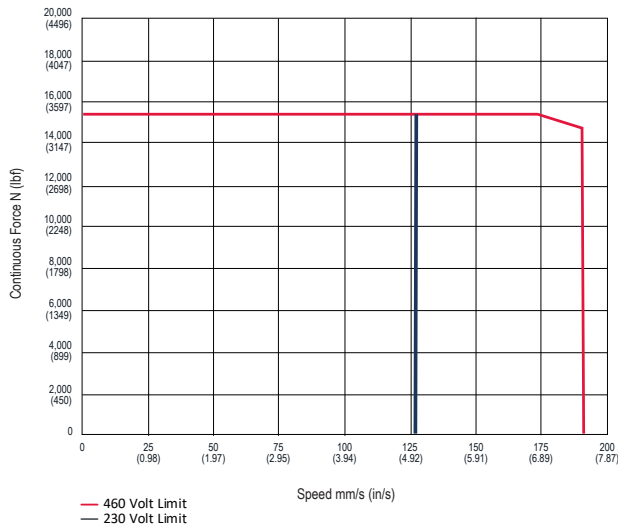

Exlar GTX100 - 05
12.7 mm (0.5 in) Screw Lead

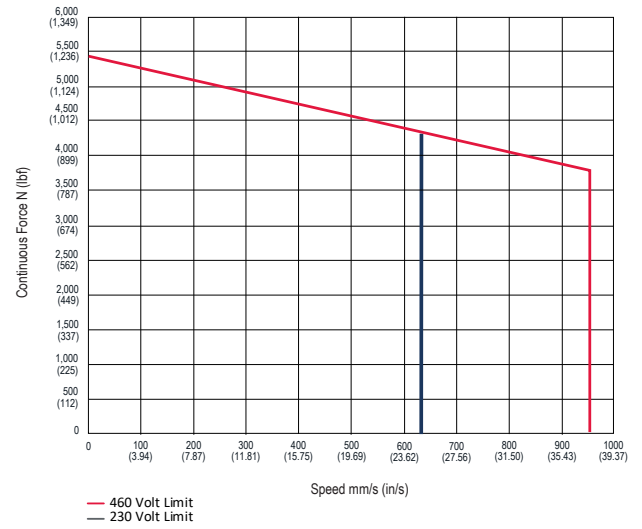

Exlar GTX100 - 02
5.08 mm (0.2 in) Screw Lead

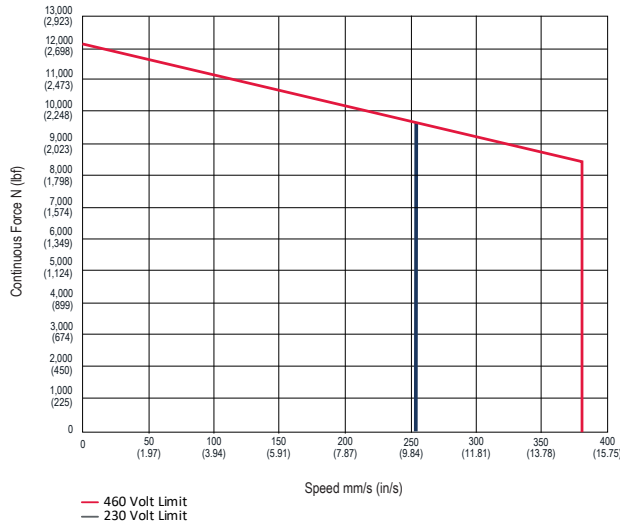

Options

Motor Winding / Voltage

Exlar GTX actuators can be operated at a wide range of voltages (up to 460 Vac). For DC voltage applications, please refer to the order guide “D” callout. Refer to the mechanical/electrical specifications for motor torque and actuator rated force.

4	460 Vac Max
D	48 Vdc Max

Internal Holding Brake

This option provides an internal holding brake for Exlar GTX actuators. The brake is a permanent magnet brake that is normally engaged. Power must be applied to the brake to disengage the brake.

Feedback Device Options:

- Resolvers
- Incremental Encoders
- Absolute Encoders

Exlar GTX actuators are compatible with a variety of drive platforms available today. We install, aligns, and wires feedback devices to mimic a typical motor’s wiring and cabling commonly used with the listed amplifier manufacturer (see wiring and alignment section for details). If your wiring and alignment is not listed, please consult Exlar.

External Anti-rotate Assembly

The unique design of the Exlar GTX linear actuators permits the extending rod to rotate. This capability simplifies setup by allowing the user to rotate the rod in and out of the actuator for mechanical attachment or system testing.

However, this feature also requires that once setup and testing are completed, the rod be kept from rotating so proper linear motion will be maintained. In most applications the actuator’s load is coupled to linear bearings, or some other support device. In these cases the load cannot rotate, so an anti-rotation on the actuator is not needed.

Splined Rod Option

The splined rod is an internal anti-rotate option that will restrict rotation but still provide linear motion without the need for an external mechanism. It is not suitable for environments where contaminants may be able to penetrate the actuator. The option does NOT meet the IP66S rating as there is no sealing component where the driven rod extends and retracts. If the unit is installed vertically rod end down there is potential for grease to exit the unit in environments where overheating can occur.

Stainless Steel Rod Options

All thread options on the Exlar GTX product line are available in 17-4 stainless steel. This option provides improved corrosion resistance for the main rod of the actuator. This option can be beneficial in applications where the rod could be exposed to harsh chemicals or outdoor environments.

Mounting Options

Both as part of the actuator model code and sold as accessory kits. For applications in which the load is free to rotate, Exlar offers bolt-on anti-rotation systems.

External Limit Switch/ Anti-Rotate Assembly

This option allows external limit switches to be mounted to the Exlar GTX Actuator. These switches provide travel indication to the controller and are adjustable (Limit switches sold separately).

The external limit switch accessory for the Exlar GTX linear actuators allows the user to externally mount adjustable switches for use as the end of travel limit switches or home position sensors. (Limit switches sold separately from actuator)

NOTE: Accessory option “L” required in model mask to order

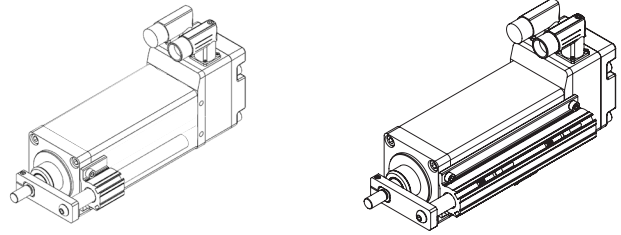

Switch Type	Exlar Part Number	Turck Part Number
Normally Closed Switch, PNP	43404	BIM-UNT-RP6X
Normally Open Switch, PNP	43403	BIM-UNT-AP6X
Normally Closed Switch, NPN	67635	BIM-UNT-RN6X
Normally Open Switch, NPN	67634	BIM-UNT-AN6X

Dimensions

Exlar GTX060

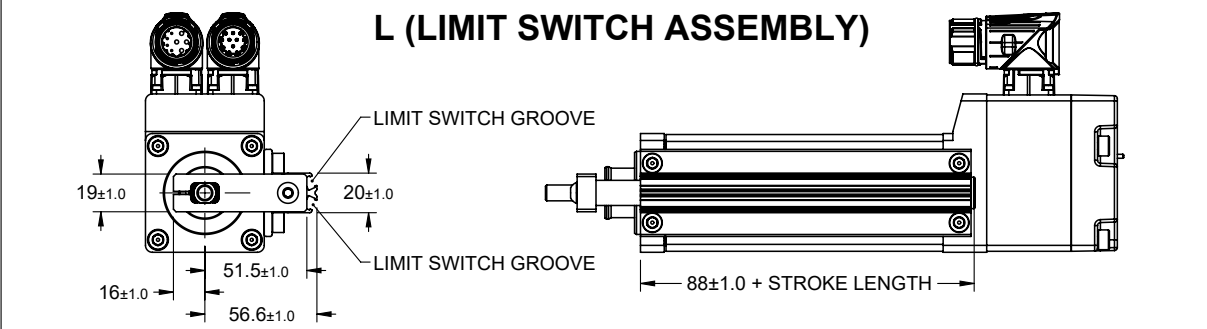
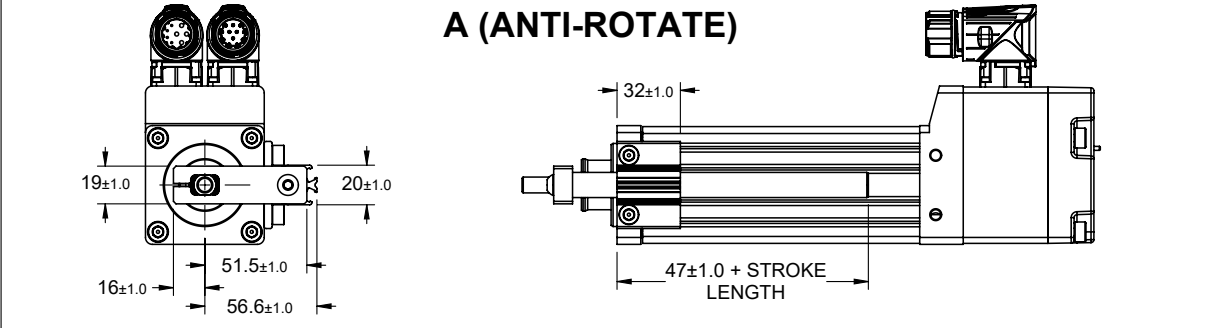
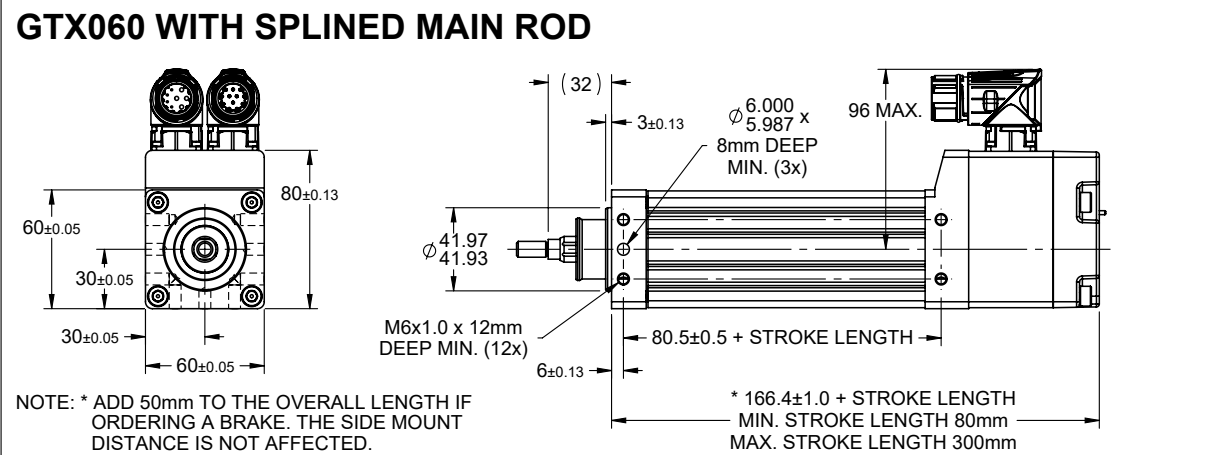
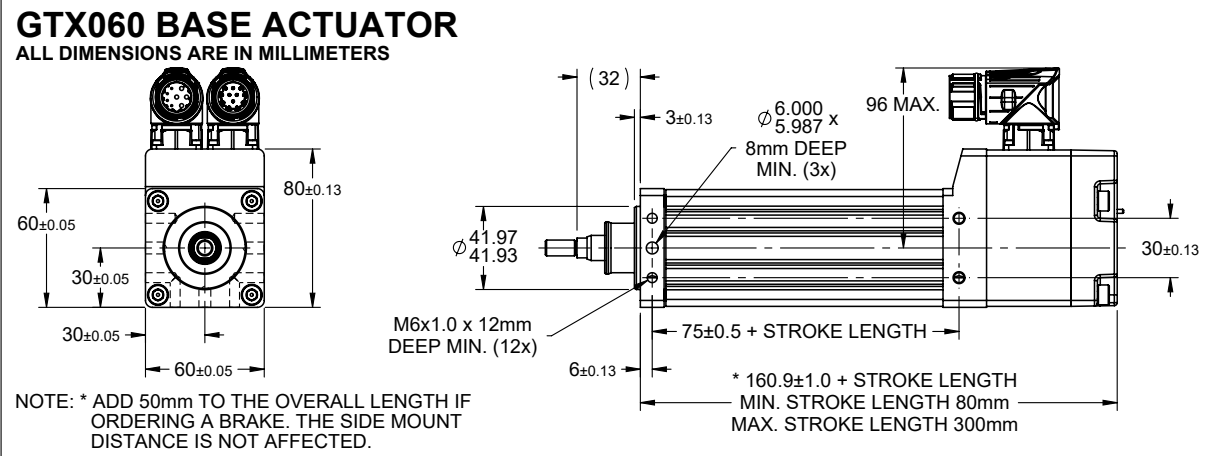

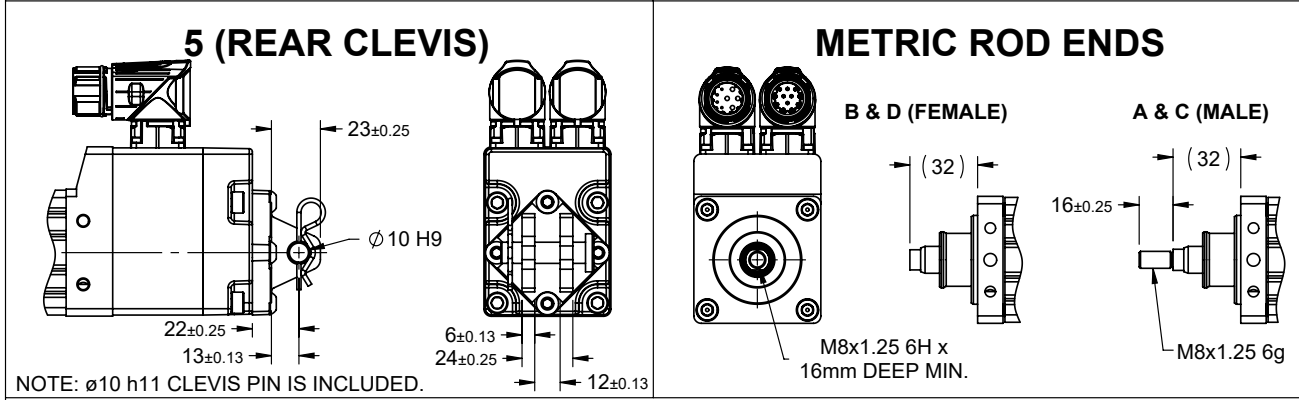
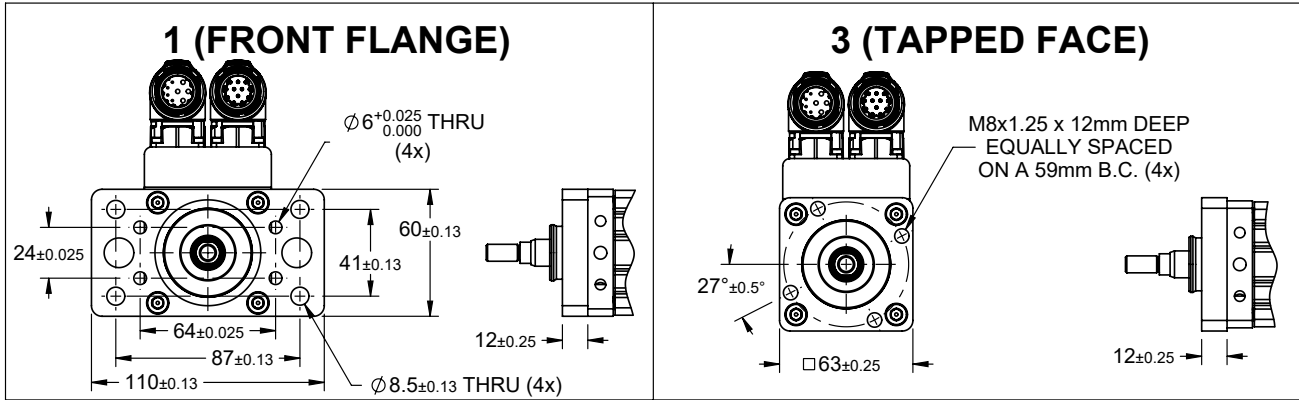

GTX060 IMPERIAL OPTIONS

ALL DIMENSIONS ARE IN INCHES

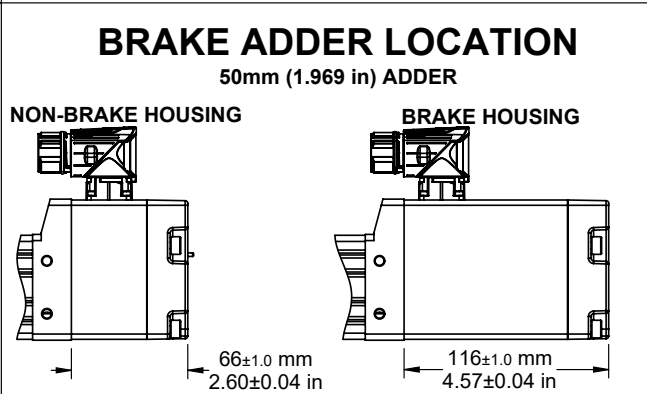
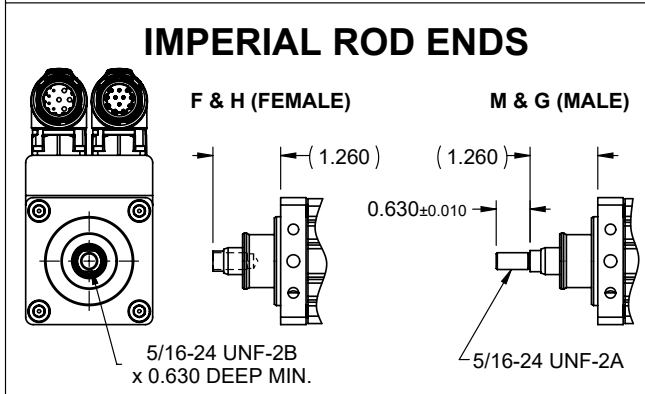
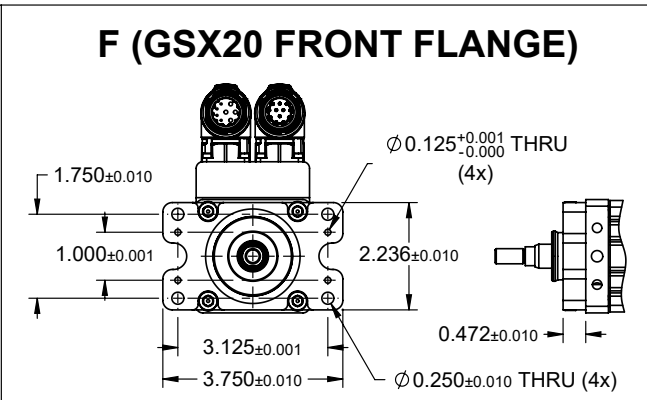
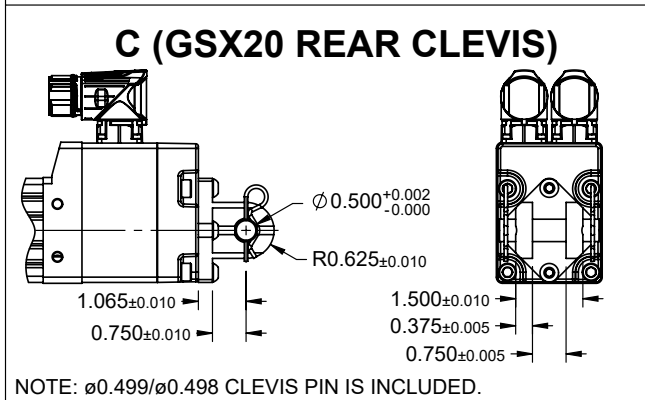

Exlar GTX080

GTX080 BASE ACTUATOR

ALL DIMENSIONS ARE IN MILLIMETERS

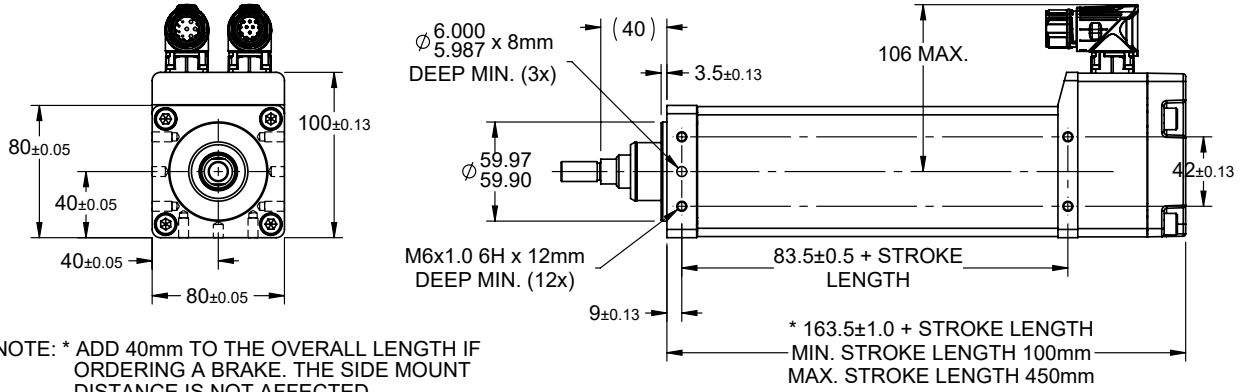

GTX080 WITH SPLINED MAIN ROD

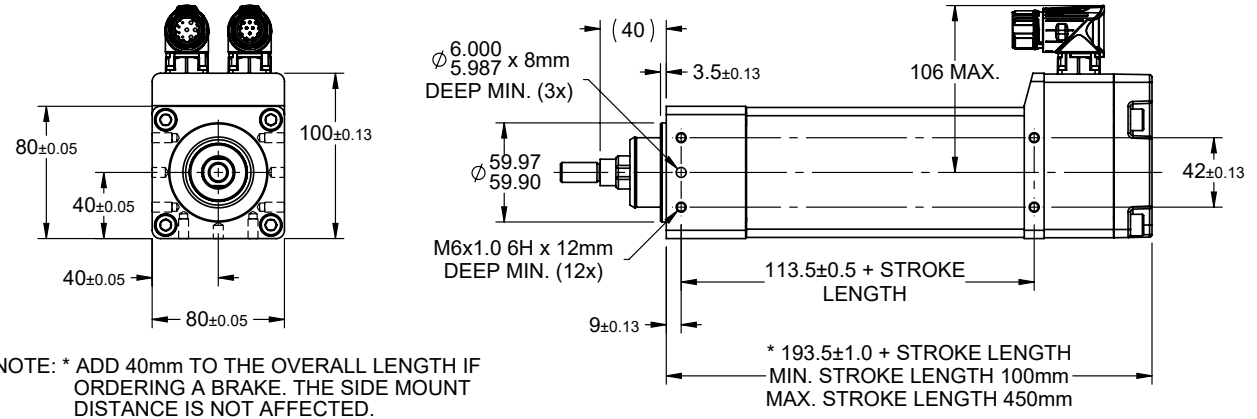

A (ANTI-ROTATE)

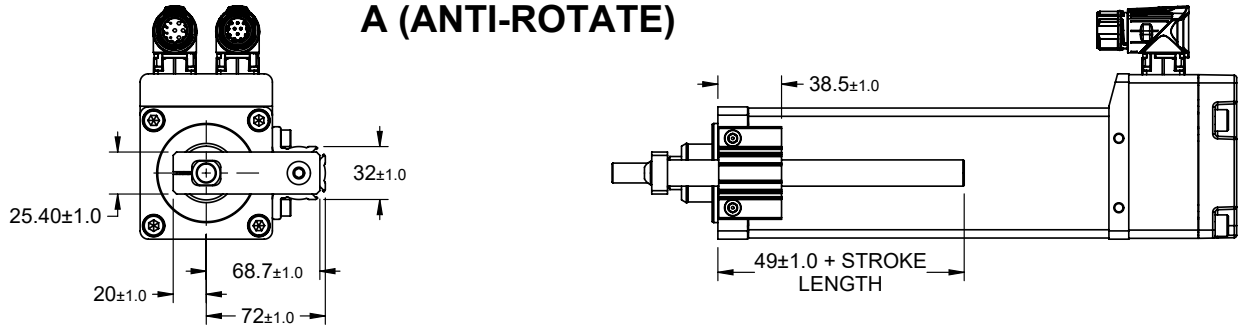

L (LIMIT SWITCH ASSEMBLY)

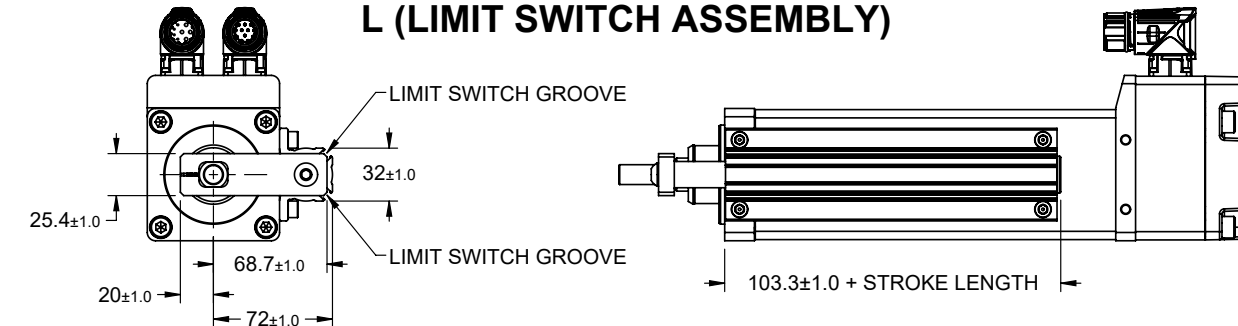

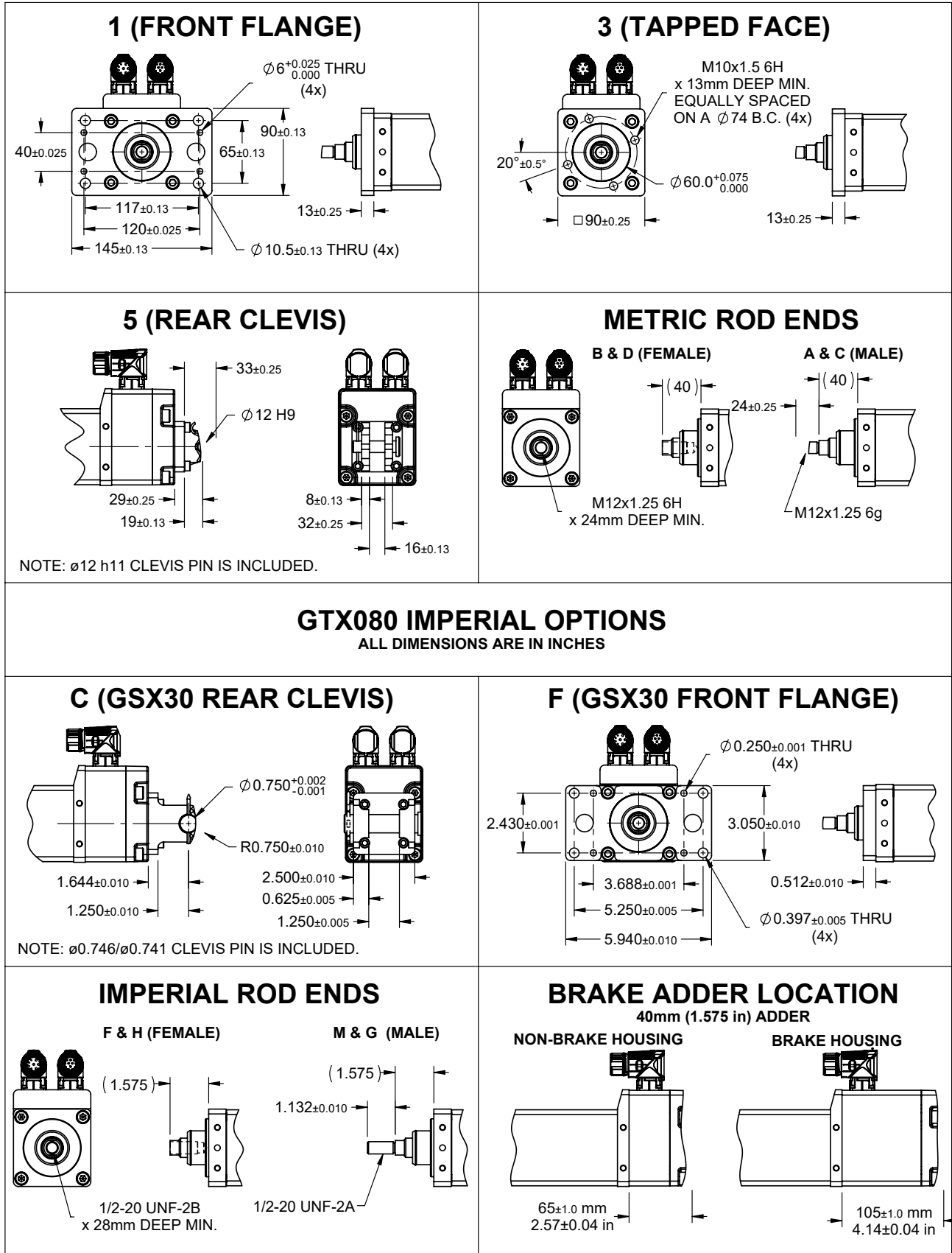

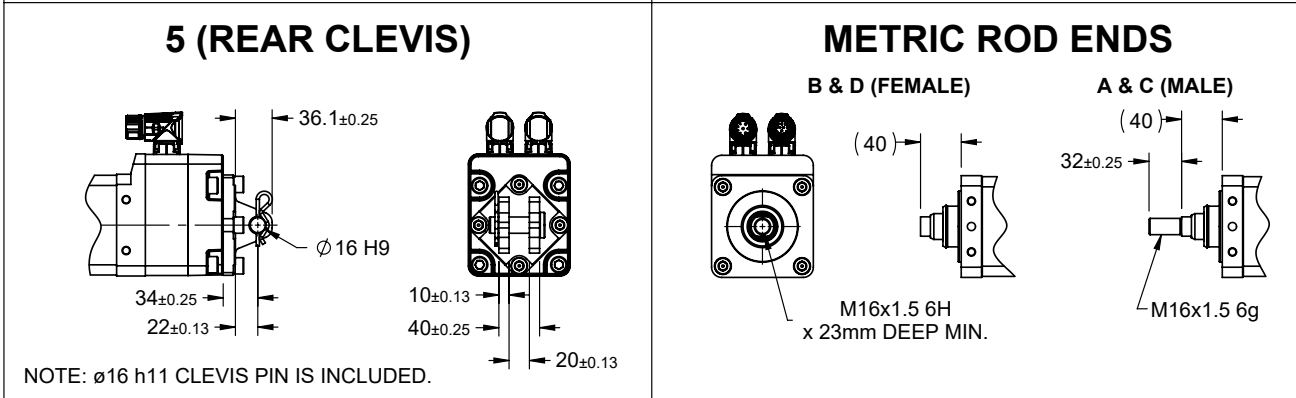
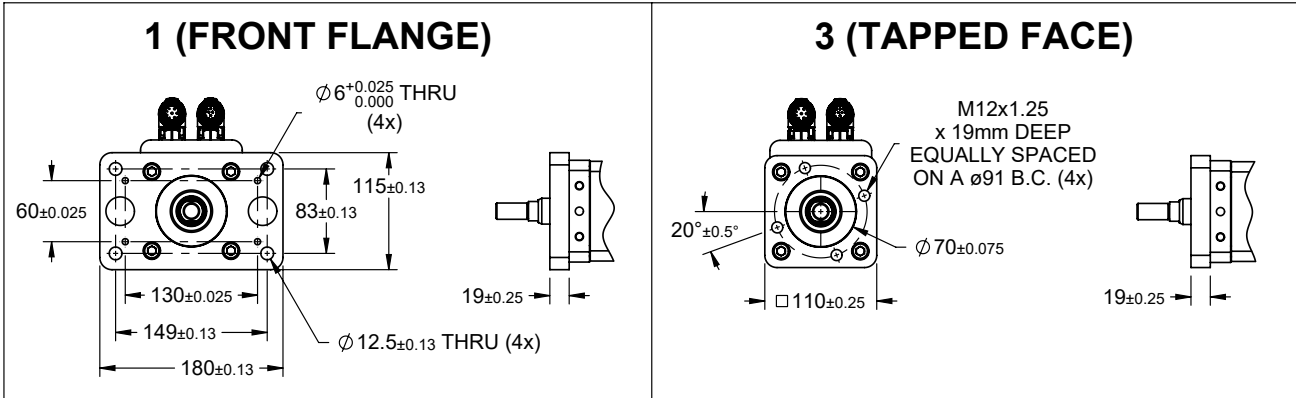

GTX100 IMPERIAL OPTIONS

ALL DIMENSIONS ARE IN INCHES

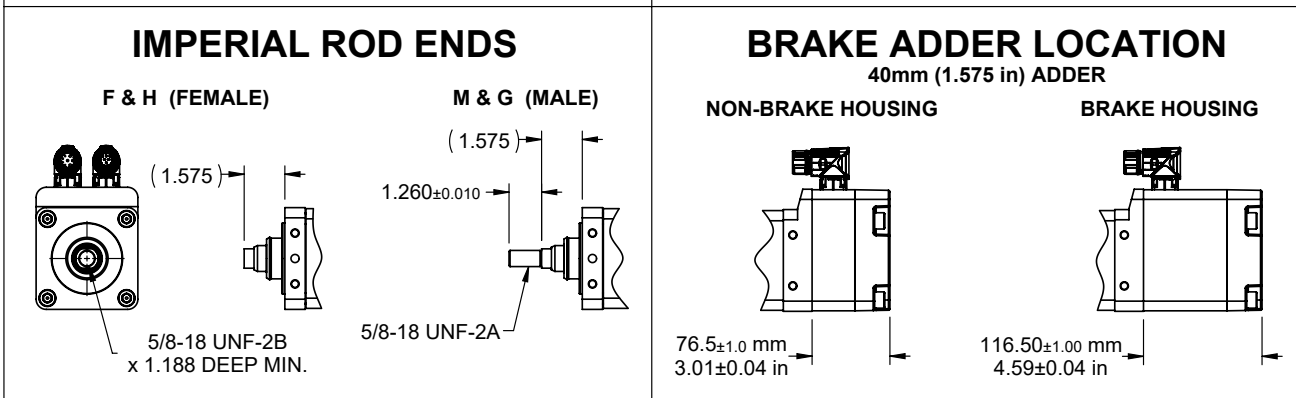
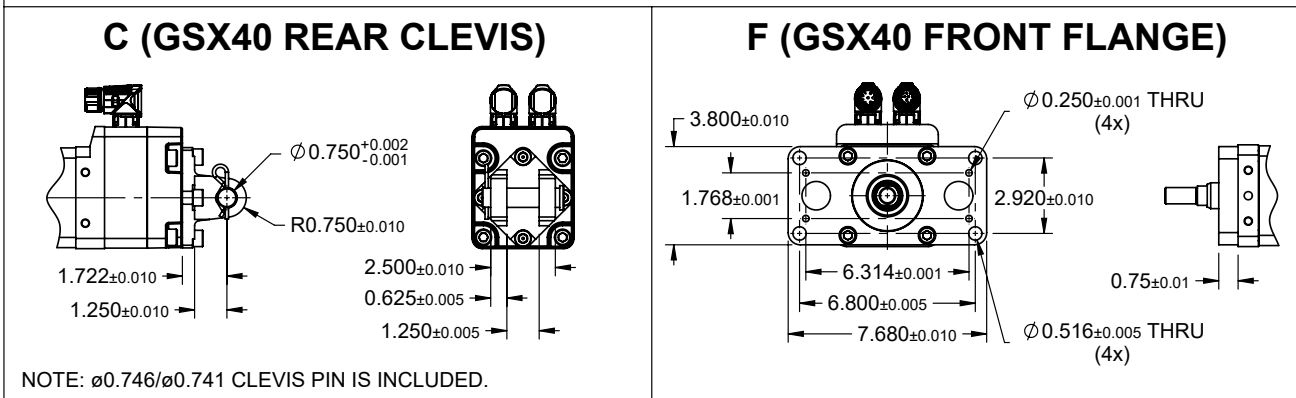

SPHERICAL ROD EYE

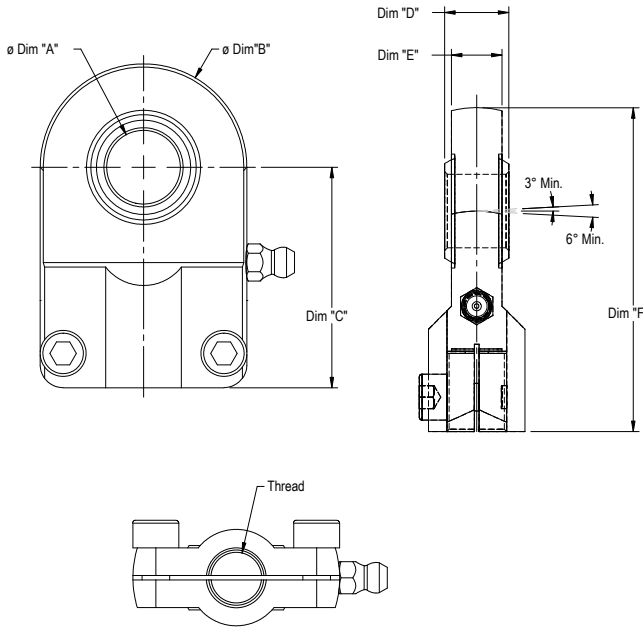

	Exlar GTX Dimensional Specs		
	060	080	100
ø Dim "A"	<u>8.065</u> 7.988	<u>16.000</u> 15.992	<u>25.021</u> 25.000
ø Dim "B"	22.25	45.0	65.0
Dim "C"	36.0	48.0	68.0
Dim "D"	12.0	14.0	20.0
Dim "E"	8.0	11.0	17.0
Dim "F"	47.1	70.5	100.5
Thread	M8x1.2	M12x1.25	M16x1.5
Weight (kg)	0.21	0.21	0.66

ROD END CODE "A" IS REQUIRED ON THE ACTUATOR

SPHERICAL ROD EYE

FRAME SIZE	ORDER CODE
060	GTX060-RE1-KIT
080	GTX080-RE1-KIT
100	GTX100-RE1-KIT

ROD CLEVIS

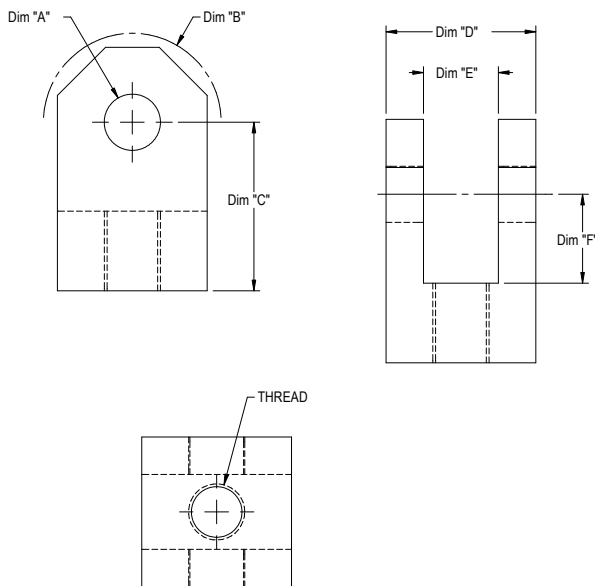

	Exlar GTX Dimensional Specs		
	060	080	100
ø Dim "A"	<u>8.065</u> 7.988	<u>12.043</u> 12.000	<u>20.052</u> 20.000
ø Dim "B"	20.0	34.0	58.0
Dim "C"	32.0	36.0	54.0
Dim "D"	16.0	34.0	52.0
Dim "E"	8.0	16.0	30.0
Dim "F"	16.0	19.0	32.0
Thread	M8x1.25	M12x1.25	M16x1.5
Weight (kg)	0.25	0.25	1.0

ROD END CODE "A" IS REQUIRED ON THE ACTUATOR

CLEVIS ROD EYE

FRAME SIZE	ORDER CODE
060	GTX060-RC1-KIT
080	GTX080-RC1-KIT
100	GTX100-RC1-KIT

Feedback Types for Exlar GTX

Drive / Feedback Designator Callouts

Drive Manufacturers	Wiring & Alignment Code	Resolver	Incremental Encoder	SICK Hiperface Absolute Encoder	SICK Hiperface DSL Absolute Encoder	Heidenhain Endat 2.1 Absolute Encoder ¹	Heidenhain Endat 2.2 Absolute Encoder ²
AMK	AK	R1A1				H1A1	
B&R Automation	BR	R1A1				H1A2	H3A8 ³
Baldor	BD	R1A1				H1A1	
Baumuller	BM	R1A1		S1A1		H1A2	
Beckhoff Automation	BE				S4C0 ³	H1A2	H3C2 ³
Control Techniques / Nidec	CT	R2B1	E1B2	S1B1		H1B2	
Elau / Schneider	EU			S1A1 ⁴			
Elmo Motion Control	EL	R1B1	E1B2			H1B2	
Curtiss-Wright Exlar	EX	R1A1	E1A2	S1A2		H1A2	
Infranor	IF	R1B2		S1B2			
Bosch-Rexroth	IN			S2D3 ⁴		H1D3	
Kollmorgen	KM	R2A1	E1A2			H1A2	
LTI	LS	R2A1		S1A2			
Lenze	LZ	R1B1		S1B1			
Parker	PC	R1B1	E1B2			H1B2	
Rockwell Automation	RA		E1C2	S1C2 ⁴	S3C0 ⁴		
Siemens	SM	R1B1				H1B2	
Stober Drives	SB	R4A1				H1A1	

¹Synchronous serial EnDat 2.1 with 1 Vpp Incremental Signals (EnDat01)

²Synchronous serial EnDat 2.2 without Incremental Signals (EnDat22)

³Supports Functional Safety

⁴Encoder is pre-programmed for operation with the manufacturer's servo drives.

Feedbacks	
R1 – Resolver, 2-pole, 5 kHz, 4 V	S2 – SICK Hiperface, SKM36 Multi-turn Absolute Encoder, 18-bit, Bosch-Rexroth
R2 – Resolver, 2-pole, 7 kHz, 4.25 V	S3 – SICK Hiperface DSL, EKM36 Multi-turn Absolute Encoder, 18-bit
R4 - Resolver, 2-pole, 10 kHz, 7 V, Transformation Ratio 0.5±5%	S4 – SICK Hiperface DSL, EKM36 Multi-turn Absolute Encoder, 18-bit, Functional Safety
E1 – Incremental Encoder, 2048 PPR (8192 counts), 8-pole, 5 V, Index Pulse, Hall commutation, 5 Vdc	H1 – Heidenhain EnDat 2.1, EQN 1125 Multi-turn Absolute Encoder, 13-bit
S1 – SICK Hiperface, SKM36 Multi-turn Absolute Encoder, 18-bit	H3 – Heidenhain EnDat 2.2, EQN 1135 Multi-turn Absolute Encoder, 23-bit, Functional Safety

Power Connectors	Feedback Connectors
A = 8 pin M23 Size 1, Right Angle Connector, TE BEDC110MR11001216000 or equiv.	0 = Feedback signal wired through power connector
B = 6 pin M23 Size 1, Right Angle Connector, TE BEDC106MR14001216000 or equiv.	1 = 12 pin M23 Size 1, P Type, Right Angle Connector, TE AEDC052MS06001215000 or equiv.
C = 9 pin M23 Size 1, Right Angle Connector, TE BEDC091MR30001216000 or equiv.	2 = 17 pin M23 Size 1, E Type, Right Angle Connector, TE AEDC113MS06001215000 or equiv.
D = 4+5 pin M23 size 1, Right Angle Connector, Bosch Rexroth R911309687	3 = 10 pin M23 Size 1, Right Angle Connector, Bosch Rexroth R911309733
	5 = 8 pin M12, Straight Connector
	8 = 12 pin M23 Size 1, Series 615 ITEC, Right Angle Connector, TE EED-A001MR02000600000 or equiv.

Wiring and Alignment Options

AMK-Resolver (AK-R1A1) - Standard Resolver w/M23 connectors

Power Connector Pin-Out		Pin Side View
Pin Number	Signal	
1	U	
2	PE	
3	W	
4	V	
A	TH	
B	TH	
C	BR +	
D	BR 0V	

Feedback Connector Pin-Out		Pin Side View
Pin Number	Signal	
1	+ Sin	
2	- Sin	
3	+ Cos	
4	- Cos	
5	-	
6	-	
7	-	
8	Shield	
9	+ UREF	
10	- UREF	
11	-	
12	-	
Actuator Case	-	

B & R Automation-Resolver (BR-R1A1) - Standard Resolver w/M23 connectors

Power Connector Pin-Out		Pin Side View
Pin Number	Signal	
1	U	
2	PE	
3	W	
4	V	
A	PT1000	
B	PT1000	
C	Brake+	
D	Brake-	

Feedback Connector Pin-Out		Pin Side View
Pin Number	Signal	
1	-	
2	-	
3	Cos+	
4	Sin+	
5	Ref+	
6	-	
7	Cos-	
8	Sin-	
9	Ref-	
10	-	
11	-	
12	-	
Actuator Case	-	

Mfg's Cable Part Number- 8CRXXX.12-1

AMK-Heidenhain (AK-H1A1) - EnDat 2.1 Heidenhain EQN1125 multi-turn absolute encoder – ED/EK motor wiring w/M23 connectors

Power Connector Pin-Out		Pin Side View
Pin Number	Signal	
1	U	
2	PE	
3	W	
4	V	
A	TH	
B	TH	
C	BR +	
D	BR 0V	

Feedback Connector Pin-Out		Pin Side View
Pin Number	Signal	
1	G2N	
2	G2I	
3	G1N	
4	G1I	
5	05P	
6	GND	
7	CLK+	
8	CLK-	
9	DAT+	
10	DAT-	
11	05P	
12	GND	
Actuator Case	-	

B & R Automation-Heidenhain (BR-H1A2) - EnDat 2.1 Heidenhain EQN1125 multi-turn absolute encoder – 8LS/8LM motor wiring w/M23 connectors

Power Connector Pin-Out		Pin Side View
Pin Number	Signal	
1	U	
2	PE	
3	W	
4	V	
A	PT1000	
B	PT1000	
C	Brake+	
D	Brake-	

Feedback Connector Pin-Out		Pin Side View
Pin Number	Signal	
1	Up Sense	
2	-	
3	-	
4	0V Sense	
5	-	
6	-	
7	Up voltage supply	
8	Clock	
9	Clock-	
10	0V voltage supply	
11	-	
12	B+	
13	B-	
14	Data	
15	A+	
16	A-	
17	Data-	
Actuator Case	-	

Mfg's Cable Part Number- 8CEXXX.12-1

B & R Automation-Heidenhain (BR-H3A8) - EnDat 2.2 Heidenhain EQN1135 multi-turn absolute encoder – Functional Safety w/M23 connectors

Power Connector Pin-Out		Pin Side View
Pin Number	Signal	
1	U	
2	PE	
3	W	
4	V	
A	PT1000	
B	PT1000	
C	Brake+	
D	Brake-	

Feedback Connector Pin-Out		Pin Side View
Pin Number	Signal	
1	12.5VDC	
2	D	
3	D/	
4	T	
5	T/	
6	-	
7	Com 1	
8	-	
9	-	
10	-	
11	-	
12	-	

Baldor-Heidenhain (BD-H1A1) - EnDat 2.1 Heidenhain EQN1125 multi-turn absolute encoder – ED/EK motor wiring w/M23 connectors

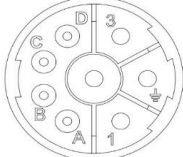
Power Connector Pin-Out		Pin Side View
Pin Number	Signal	
1	T1	
2	Earth/Ground	
3	T3	
4	T2	
A	Thermal Switch	
B	Thermal Switch	
C	Brake+	
D	Brake-	

Feedback Connector Pin-Out		Pin Side View
Pin Number	Signal	
1	Data-	
2	Sin+	
3	0	
4	Cos+	
5	Clock-	
6	-	
7	Clock+	
8	Cos-	
9	5 volt	
10	DGND	
11	Sin-	
12	Data+	
Actuator Case	-	

Baldor-Resolver (BD-R1A1) - Standard Resolver w/M23 connectors

Power Connector Pin-Out		Pin Side View
Pin Number	Signal	
1	U	
2	GND	
3	W	
4	V	
A	Therm	
B	Therm	
C	Brake+	
D	Brake-	

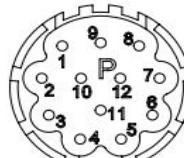
Feedback Connector Pin-Out		Pin Side View
Pin Number	Signal	
1	R1 Ref Hi	
2	R2 Ref Lo	
3	S1 Cos+	
4	S3 Cos-	
5	S2 Sin+	
6	S4 Sin-	
7	-	
8	-	
9	-	
10	-	
11	-	
12	-	
Actuator Case	Shield	

Baumuellor-Resolver (BM-R1A1) - Standard Resolver w/M23 connectors

Power Connector Pin-Out		Pin Side View
Pin Number	Signal	
1	Phase U	
2	PE	
3	Phase W	
4	Phase V	
A	Brake+	
B	Brake-	
C	-	
D	-	

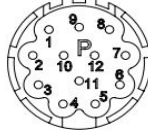
Feedback Connector Pin-Out		Pin Side View
Pin Number	Signal	
1	Cos -	
2	-	
3	-	
4	-	
5	Sin -	
6	Sin +	
7	-	
8	Cos +	
9	-	
10	Ref +	
11	-	
12	Ref -	
Actuator Case	Shield	

Baumüller-SICK (BM-S1A1) - SICK Hiperface SKM36 multi-turn absolute encoder – SH motor wiring w/M23 connectors

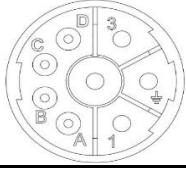
Power Connector Pin-Out		Pin Side View
Pin Number	Signal	
1	Phase U	
2	PE	
3	Phase V	
4	Phase W	
A	Brake+	
B	Brake-	
C	PT1000	
D	PT1000	

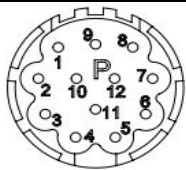
Feedback Connector Pin-Out		Pin Side View
Pin Number	Signal	
1	Ref Cos	
2	Daten +	
3	-	
4	-	
5	Sin	
6	Ref Sin	
7	Daten -	
8	Cos	
9	-	
10	GND	
11	-	
12	+V	
Actuator Case	-	

Baumüller-Heidenhain (BM-H1A2) - EnDat 2.1 Heidenhain EQN1125 multi-turn absolute encoder – 8LS/8LM motor wiring w/M23 connectors

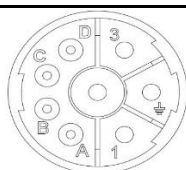
Power Connector Pin-Out		Pin Side View
Pin Number	Signal	
1	Phase U	
2	PE	
3	Phase V	
4	Phase W	
A	Brake+	
B	Brake-	
C	-	
D	-	

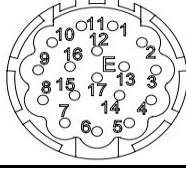
Feedback Connector Pin-Out		Pin Side View
Pin Number	Signal	
1	Up Sense	
2	-	
3	-	
4	0V Sense	
5	PT1000	
6	PT1000	
7	Up voltage supply	
8	Clock	
9	Clock -	
10	0V voltage supply	
11	-	
12	B+	
13	B-	
14	Data	
15	A+	
16	A-	
17	Data -	
Actuator Case	-	

Beckhoff Automation-Heidenhain (BE-S4C0) - SICK Hiperface DSL, EKM36 Multi-turn Absolute Encoder, 18-bit, Functional Safety

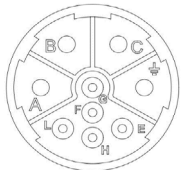
Power Connector Pin-Out		Pin Side View
Pin Number	Signal	
A	U	
B	V	
C	W	
D	PE	
E	PT1000-/OCT-	
F	Shield	
G	Brake+	
H	PT1000+/OCT+	
L	Brake-	OCT Cable: ZK4800-8023-xxxx ZK4800-8024-xxxx

Beckhoff Automation-Heidenhain (BE-H1A2) - EnDat 2.1 Heidenhain EQN1125 multi-turn absolute encoder – AM3XXXX motor wiring w/M23 connectors

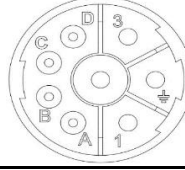
Power Connector Pin-Out		Pin Side View
Pin Number	Signal	
1	U	
2	PE	
3	W	
4	V	
A	Brake+	
B	Brake-	
C	PT1000	
D	PT1000	

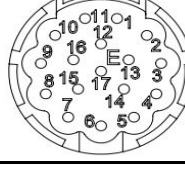
Feedback Connector Pin-Out		Pin Side View
Pin Number	Signal	
1	B-	
2	0V voltage supply	
3	A-	
4	Up voltage supply	
5	Data	
6	-	
7	-	
8	Clock	
9	B+	
10	0V Sense	
11	A+	
12	Up Sense	
13	Data -	
14	-	
15	Clock -	
16	-	
17	-	
Actuator Case	-	

Beckhoff Automation-Heidenhain (BE-H3C2) - EnDat 2.2 Heidenhain EQN1135 multi-turn absolute encoder – 23 bit, Functional Safety w/M23 connectors

Power Connector Pin-Out		Pin Side View
Pin Number	Signal	
A	U	
	V	
C	W	
D	PE	
E	PT1000-	
F	Shield	
G	Brake+	
H	PT1000+	
L	Brake-	

Power cable: ZK4800-8023-xxxx
ZK4800-8024-xxxx

Feedback Connector Pin-Out		Pin Side View
Pin Number	Signal	
1	-	
2	GND	
3	-	
4	5 Vdc (±10%)	
5	Data; DX+ Data	
6	Us 11 Vdc	
7	-	
8	Clock; CLK+	
9	-	
10	GND sense	
11	-	
12	5V sense	
13	Data; DX-	
14	-	
15	Clock; CLK-	
16	-	
17	-	
Actuator Case	-	

Feedback Cable: ZK4810-8020-xxxx
ZK4810-8020-xxxx

Control Techniques-Encoder (CT-E1B2) - Standard Incremental Encoder – FM/HD motor wiring w/M23 connectors

Power Connector Pin-Out		Pin Side View
Pin Number	Signal	
1	R	
2	S	
¥	GND	
4	T	
5	Brake+	
6	Brake-	

Feedback Connector Pin-Out		Pin Side View
Pin Number	Signal	
1	Therm Switch	
2	Therm Switch	
3	-	
4	U	
5	U/	
6	V	
7	V/	
8	W	
9	W/	
10	A	
11	Z	
12	Z/	
13	A/	
14	B	
15	B/	
16	+ 5 VDC	
17	0V	
Actuator Case	-	

Mfg's Cable Part Number- S1BAAAXXX

Control Techniques-Resolver (CT-R2B1) - Standard Resolver – FM/HD motor wiring w/M23 connectors

Power Connector Pin-Out		Pin Side View
Pin Number	Signal	
1	R	
2	S	
¥	GND	
4	T	
5	Brake+	
6	Brake-	

Feedback Connector Pin-Out		Pin Side View
Pin Number	Signal	
1	Excitation High	
2	Excitation Low	
3	Cos High	
4	Cos Low	
5	Sin High	
6	Sin Low	
7	Therm Switch	
8	Therm Switch	
9	-	
10	-	
11	-	
12	-	
Actuator Case	Shield	

Mfg's Cable Part Number SRBBBBXXXX / SRBBABXXXX

Control Techniques-SICK (CT-S1B1)– SICK Hiperface SKM36 multi-turn absolute encoder – FM/HD motor wiring w/M23 connectors

Power Connector Pin-Out		Pin Side View
Pin Number	Signal	
1	R	
2	S	
¥	GND	
4	T	
5	Brake+	
6	Brake-	

Feedback Connector Pin-Out		Pin Side View
Pin Number	Signal	
1	Ref Cos	
2	Daten +	
3	Daten -	
4	Cos	
5	Sin	
6	Ref Sin	
7	Therm Switch	
8	Therm Switch	
9	Screen	
10	Com	
11	-	
12	+V	
Actuator Case	-	

Mfg's Cable Part Number- SSBCABXXXX

Control Techniques-Heidenhain (CT-H1B2) - EnDat 2.1 Heidenhain EQN1125 multi-turn absolute encoder Unidrive M75x w/M23 connectors

Power Connector Pin-Out		Pin Side View
Pin Number	Signal	
1	R	
2	S	
Ⓜ	GND	
4	T	
5	Brake+	
6	Brake-	

Feedback Connector Pin-Out		Pin Side View
Pin Number	Signal	
1	PT1000	
2	PT1000	
3	-	
4	-	
5	-	
6	-	
7	-	
8	Clock +	
9	Clock -	
10	A+	
11	Data +	
12	Data -	
13	A-	
14	B+	
15	B-	
16	+ 5 VDC	
17	COM	
Actuator Case	Shield	

Elau-SICK (EU-S1A1) - SICK Hiperface SKM36 multi-turn absolute encoder - SH motor wiring w/M23 connectors

Power Connector Pin-Out		Pin Side View
Pin Number	Signal	
1	U (1)	
2	PE	
3	W (3)	
4	V (2)	
A	br+ (8)	
B	br- (7)	
C	PT1000	
D	PT1000	

Feedback Connector Pin-Out		Pin Side View
Pin Number	Signal	
1	REFCOS	
2	RS485+	
3	-	
4	-	
5	SIN	
6	REFSIN	
7	RS485-	
8	COS	
9	-	
10	GND	
11	-	
12	Us	
Actuator Case	-	

Mfg's Cable Part Number- SH Series Absolute Encoder Cable

Elmo-Resolver (EL-R1B1) - Standard Resolver w/M23 connectors

Power Connector Pin-Out		Pin Side View
Pin Number	Signal	
1	M1	
2	M3	
Ⓜ	PE	
4	Brake-	
5	M2	
6	Brake+	

Feedback Connector Pin-Out		Pin Side View
Pin Number	Signal	
1	-	
2	-	
3	Sin- S4	
4	Cos- S3	
5	Ref R2	
6	-	
7	Sin+ S2	
8	Cos+ S1	
9	Ref R1	
10	-	
11	-	
12	-	
Actuator Case	Shield	

Elmo-Encoder (EL-E1B2) - Standard Incremental Encoder w/M23 connectors

Power Connector Pin-Out		Pin Side View
Pin Number	Signal	
1	M1	
2	M3	
Ⓜ	PE	
4	Brake-	
5	M2	
6	Brake+	

Feedback Connector Pin-Out		Pin Side View
Pin Number	Signal	
1	Power Supply 5V	
2	Therm Switch	
3	Power Supply 0V	
4	HC +	
5	HC -	
6	HA +	
7	HA -	
8	HB +	
9	HB -	
10	A +	
11	A -	
12	B +	
13	B -	
14	Z +	
15	Z -	
16	-	
17	Therm Switch	
Actuator Case	-	

Elmo-Heidenhain (EL-H1B2) - EnDat 2.1 Heidenhain EQN1125 multi-turn absolute encoder w/M23 connectors

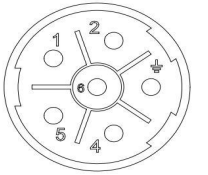
Power Connector Pin-Out		Pin Side View
Pin Number	Signal	
1	U	
2	W	
3	PE	
4	Brake-	
5	V	
6	Brake+	

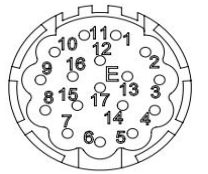
Feedback Connector Pin-Out		Pin Side View
Pin Number	Signal	
1	B-	
2	0V voltage supply	
3	A-	
4	Up voltage supply	
5	Data	
6	-	
7	Therm Switch	
8	Clock	
9	B+	
10	0V Sense	
11	A+	
12	Up Sense	
13	Data -	
14	Therm Switch	
15	Clock -	
16	-	
17	-	
Actuator Case	-	

Exlar-Encoder (EX-E1A2) - Standard Incremental Encoder 2048 Line w/ M23 connectors

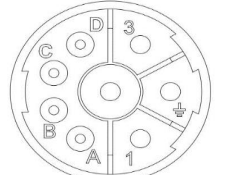
Power Connector Pin-Out		Pin Side View
Pin Number	Signal	
1	R	
2	GND	
3	T	
4	S	
A	Brake+	
B	Brake-	
C	-	
D	-	

AC (4): CBL-PWRB1-SMI-XXX
DC (D): CBL-PWRB2-SMI-XXX

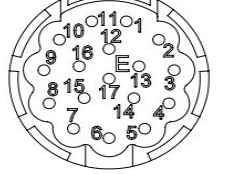
Feedback Connector Pin-Out		Pin Side View
Pin Number	Signal	
1	B-	
2	B	
3	A	
4	A-	
5	Z	
6	Z-	
7	GND	
8	Therm Switch	
9	Therm Switch	
10	+5VDC	
11	-	
12	W-	
13	V-	
14	U-	
15	W	
16	V	
17	U	
Actuator Case	-	

CBL-ENCOD-SMI-XXX

Exlar-Resolver (EX-R1A1) - Standard Resolver w/M23 connectors

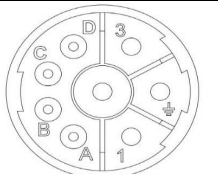
Power Connector Pin-Out		Pin Side View
Pin Number	Signal	
1	R	
2	GND	
3	T	
4	S	
A	Brake+	
B	Brake-	
C	-	
D	-	

AC (4): CBL-PWRB1-SMI-XXX
DC (D): CBL-PWRB2-SMI-XXX

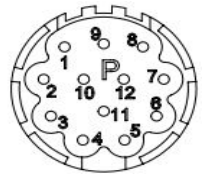
Feedback Connector Pin-Out		Pin Side View
Pin Number	Signal	
1	-	
2	Therm Switch	
3	- Cos	
4	- Sin	
5	- Exc	
6	Therm Switch	
7	+ Cos	
8	+ Sin	
9	+ Exc	
10	-	
11	-	
12	-	
Actuator Case	Shield	

CBL-RESOL-SMI-XXX

Exlar-SICK (EX-S1A2) - SICK Hiperface SKM36 multi-turn absolute encoder w/M23 connectors

Power Connector Pin-Out		Pin Side View
Pin Number	Signal	
1	R	
2	GND	
3	T	
4	S	
A	Brake+	
B	Brake-	
C	-	
D	-	

AC (4): CBL-PWRB1-SMI-XXX
DC (D): CBL-PWRB2-SMI-XXX

Feedback Connector Pin-Out		Pin Side View
Pin Number	Signal	
1	Sin +	
2	Com	
3	Cos +	
4	+ 5V	
5	Ref +	
6	-	
7	Therm Switch	
8	-	
9	Sin -	
10	-	
11	Cos -	
12	-	
13	Ref -	
14	Therm Switch	
15	-	
16	-	
17	-	
Actuator Case	-	

CBL-ABSOL-SMI-XXX

Exlar-Heidenhain (EX-H1A2) - EnDat 2.1 Heidenhain EQN1125 multi-turn absolute encoder w/M23 connectors

Power Connector Pin-Out		Pin Side View
Pin Number	Signal	
1	U	
2	PE	
3	W	
4	V	
A	Brake+	
B	Brake-	
C	-	
D	-	

AC (4): CBL-PWRB1-SMI-XXX
DC (D): CBL-PWRB2-SMI-XXX

Feedback Connector Pin-Out		Pin Side View
Pin Number	Signal	
1	B-	
2	0V voltage supply	
3	A-	
4	Up voltage supply	
5	Data+	
6	-	
7	Therm Switch	
8	Clock	
9	B	
10	0V Sense	
11	A	
12	Up Sense	
13	Data -	
14	Therm Switch	
15	Clock -	
16	-	
17	-	
Actuator Case	-	

CBL-ABSOL-SMI-XXX

Infranor-Resolver (IF-R1B2) - Standard Resolver w/M23 connectors

Power Connector Pin-Out		Pin Side View
Pin Number	Signal	
1	R	
2	S	
3	GND	
4	T	
5	Brake+	
6	Brake-	

Feedback Connector Pin-Out		Pin Side View
Pin Number	Signal	
1	S2	
2	S4	
3	S3	
4	S1	
5	R1	
6	R2	
7	-	
8	-	
9	-	
10	-	
11	-	
12	Therm	
13	Therm	
14	-	
15	-	
16	-	
17	-	
Actuator Case	-	

Infranor-SICK (IF-S1B2) - SICK Hiperface SKM36 multi-turn absolute encoder w/M23 connectors

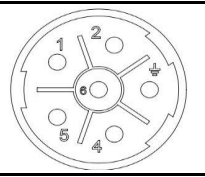
Power Connector Pin-Out		Pin Side View
Pin Number	Signal	
1	R	
2	S	
¥	GND	
4	T	
5	Brake+	
6	Brake-	

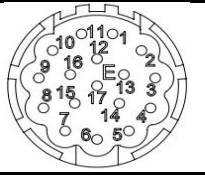
Feedback Connector Pin-Out		Pin Side View
Pin Number	Signal	
1	Sin +	
2	Sin -	
3	Cos +	
4	Cos -	
5	Ref +	
6	Ref -	
7	-	
8	-	
9	-	
10	Com	
11	+ 5V	
12	PT1000	
13	PT1000	
14	-	
15	-	
16	-	
17	0	
Actuator Case	-	

Bosch-Rexroth-Heidenhain (IN-H1D3) - EnDat 2.1 Heidenhain EQN1125 multi-turn absolute Indradrive wiring w/M23 connectors

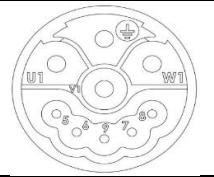
Power Connector Pin-Out		Pin Side View
Pin Number	Signal	
U1	Phase U	
V1	Phase V	
W1	Phase W	
PE	Earth	
5	PT1000	
6	PT1000	
7	Brake+	
8	Brake-	
9	-	

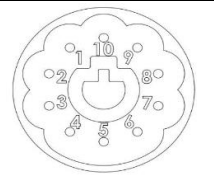
Feedback Connector Pin-Out		Pin Side View
Pin Number	Signal	
1	Vcc_Encoder	
2	GND_Encoder	
3	A+	
4	A-	
5	B+	
6	B-	
7	Data +	
8	Data -	
9	Clock	
10	Clock -	

Bosch-Rexroth-SICK (IN-S2D3) - SICK Hiperface multi-turn absolute encoder – MSK motor wiring w/M23 connectors

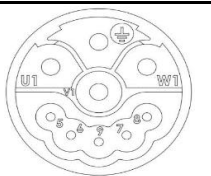
Power Connector Pin-Out		Pin Side View
Pin Number	Signal	
U1	Phase U	
V1	Phase V	
W1	Phase W	
PE	Earth	
5	PT1000	
6	PT1000	
7	Brake+	
8	Brake-	
9	-	

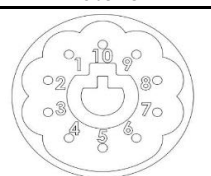
Feedback Connector Pin-Out		Pin Side View
Pin Number	Signal	
1	Vcc_Encoder	
2	GND_Encoder	
3	A+	
4	A-	
5	B+	
6	B-	
7	EncData+	
8	EncData-	
9	-	
10	-	

Mfg's Cable Part Number- RKG4200

Kollmorgen-Resolver (KM-R2A1) - Standard Resolver – AKM motor wiring w/M23 connectors

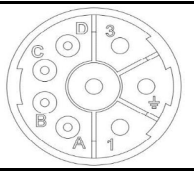
Power Connector Pin-Out		Pin Side View
Pin Number	Signal	
1	U	
2	GND	
3	W	
4	V	
A	Brake+	
B	Brake-	
C	-	
D	-	

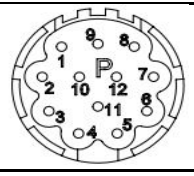
Feedback Connector Pin-Out		Pin Side View
Pin Number	Signal	
1	-	
2	Therm Switch	
3	Cos Lo (S4)	
4	Sin Lo (S3)	
5	Ref Lo (R2)	
6	Therm Switch	
7	Cos Hi (S2)	
8	Sin Hi (S1)	
9	Ref Hi (R1)	
10	-	
11	-	
12	-	
Actuator Case	Shield	

Mfg's Cable Part Number- VF-RA2474N-XX

Kollmorgen-Encoder (KM-E1A2) -
Standard Incremental Encoder – AKM motor wiring w/ M23 connectors

Power Connector Pin-Out		Pin Side View
Pin Number	Signal	
1	U	
2	PE	
3	W	
4	V	
A	Brake+	
B	Brake-	
C	-	
D	-	

Feedback Connector Pin-Out		Pin Side View
Pin Number	Signal	
1	B+	
2	B-	
3	A+	
4	A-	
5	Z	
6	Z-	
7	GND	
8	Therm Switch	
9	Therm Switch	
10	Vcc	
11	-	
12	U-	
13	V-	
14	W-	
15	U	
16	V	
17	W	
Actuator Case	-	

Mfg's Cable Part Number -
CF-CB7374N-XX

LTI-Resolver (LS-R2A1) - Standard Resolver – AKM motor wiring w/M23 connectors

Power Connector Pin-Out		Pin Side View
Pin Number	Signal	
1	U	
2	GND	
3	W	
4	V	
A	Brake+	
B	Brake-	
C	-	
D	-	

Feedback Connector Pin-Out		Pin Side View
Pin Number	Signal	
1	(S1) Cos +	
2	(S3) Cos -	
3	(S2) Sin +	
4	(S4) Sin -	
5	-	
6	(R1) Ref +	
7	(R2) Ref -	
8	-	
9	-	
10	-	
11	PT1000+	
12	PT1000-	
Actuator Case	-	

Kollmorgen-Heidenhain (KM-H1A2) - EnDat 2.1 Heidenhain EQN1125
multi-turn absolute encoder – AM3XXXX motor wiring w/M23 connectors

Power Connector Pin-Out		Pin Side View
19819 Connector	Drive Terminology	
1	U	
2	GND	
3	W	
4	V	
A	Brake+	
B	Brake-	
C	-	
D	-	

Feedback Connector Pin-Out		Pin Side View
20494 Connector	Drive Terminology	
1	B-	
2	0V voltage supply	
3	A-	
4	Up voltage supply	
5	Data	
6	-	
7	Temp.	
8	Clock	
9	B+	
10	0V Sense	
11	A+	
12	Up Sense	
13	Data -	
14	Temp.	
15	Clock -	
16	-	
17	-	
Actuator Case	-	

LTI-SICK (LS-S1A2) - SICK Hiperface SKM36 multi-turn absolute encoder w/M23 connectors

Power Connector Pin-Out		Pin Side View
Pin Number	Signal	
1	Phase U	
2	Protective Earth	
3	Phase W	
4	Phase V	
A	Brake+	
B	Brake-	
C	PT1000	
D	PT1000	

Feedback Connector Pin-Out		Pin Side View
Pin Number	Signal	
1	COS+	
2	REFCOS	
3	SIN+	
4	REFSIN	
5	-	
6	-	
7	GND	
8	-	
9	Us 7-12v	
10	Dataen+ RS485	
11	Dataen- RS485	
12	-	
13	-	
14	-	
15	-	
16	-	
17	-	
Actuator Case	-	

Lenze-Resolver (LZ-R1B1) - Standard Resolver – MCS motor wiring w/ M23 connectors

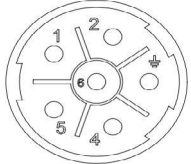
Power Connector Pin-Out		Pin Side View
Pin Number	Signal	
1	Y1 / BD1	
2	Y2 / BD2	
⌘	PI	
4	U	
5	V	
6	W	

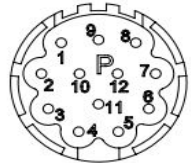
Feedback Connector Pin-Out		Pin Side View
Pin Number	Signal	
1	+ Ref	
2	- Ref	
3	-	
4	+ Cos	
5	- Cos	
6	+ Sin	
7	- Sin	
8	-	
9	-	
10	-	
11	PT1000	
12	PT1000	

Mfg's Cable Part Number- MCS Series Resolver Cable

Actuator Case	-
---------------	---

Parker-Resolver (PC-R1B1) - Standard Resolver – SMH motor wiring w/ M23 connectors

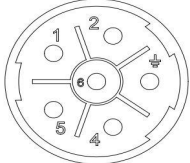
Power Connector Pin-Out		Pin Side View
Pin Number	Signal	
1	U	
2	V	
⌘	PE	
4	Brake+	
5	Brake-	
6	W	

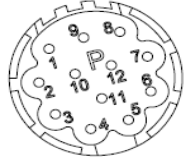
Feedback Connector Pin-Out		Pin Side View
Pin Number	Signal	
1	Sin -	
2	Sin +	
3	-	
4	-	
5	-	
6	-	
7	Ref -	
8	PT1000	
9	PT1000	
10	Ref +	
11	Cos +	
12	Cos -	

Mfg's Cable Part Number- SMH Series Incremental Encoder Cable

Actuator Case	Shield
---------------	--------

Lenze-Encoder (LZ-S1B1) - SICK Hiperface SKM36 multi-turn absolute encoder w/M23 connectors

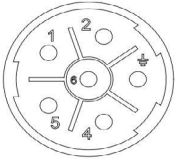
Power Connector Pin-Out		Pin Side View
Pin Number	Signal	
1	Y1 / BD1	
2	Y2 / BD2	
⌘	PI	
4	U	
5	V	
6	W	

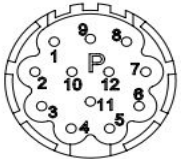
Feedback Connector Pin-Out		Pin Side View
Pin Number	Signal	
1	+ SIN	
2	- COS	
3	+ COS	
4	+ 8 V	
5	Mass	
6	- RS485	
7	+ RS485	
8	-	
9	- SIN	
10	-	
11	PT1000	
12	PT1000	

Mfg's Cable Part Number- MCS Series Absolute Encoder Cable

Actuator Case	-
---------------	---

Parker-Encoder (PC-E1B2) - Standard Incremental Encoder – MPP series motor wiring w/M23 connectors

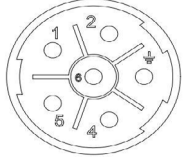
Power Connector Pin-Out		Pin Side View
Pin Number	Signal	
1	U	
2	W	
⌘	PE	
4	Brake+	
5	Brake-	
6	V	

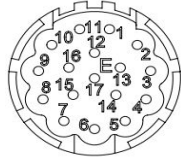
Feedback Connector Pin-Out		Pin Side View
Pin Number	Signal	
1	A-	
2	A+	
3	-	
4	Hall 1	
5	Hall 3	
6	Hall 2	
7	Ground	
8	+5 vdc	
9	Therm Switch	
10	-	
11	B	
12	B -	
13	Therm Switch	
14	-	
15	Z+	
16	Z-	
17	-	

Mfg's Cable Part Number- SMH Series Resolver Cable

Actuator Case	-
---------------	---

Parker-Heidenhain (PC-H1B2) - EnDat 2.1 Heidenhain EQN1125
multi-turn absolute encoder w/M23 connectors

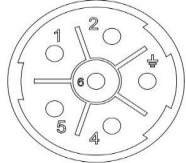
Power Connector Pin-Out		Pin Side View
Pin Number	Signal	
1	U	
2	V	
3	GND	
4	Brake+	
5	Brake-	
6	W	

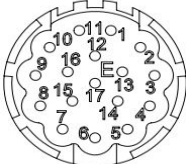
Feedback Connector Pin-Out		Pin Side View
Pin Number	Signal	
1	CH A-	
2	CH A+	
3	-	
4	CLK +	
5	CLK -	
6	-	
7	Ground	
8	Vcc	
9	Therm	
10	-	
11	CH B+	
12	CH B-	
13	Therm	
14	Up	
15	Data +	
16	Data -	
17	-	
Actuator Case	-	

Rockwell Automation-Encoder (RA-E1C2) - Standard Incremental
Encoder - MPL Type M feedback w/M23 connectors

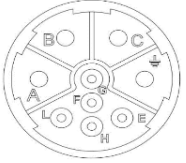
Power Connector Pin-Out		Pin Side View
Pin Number	Signal	
A	Phase U	
B	Phase V	
C	Phase W	
D	Ground	
E	-	
F	Brake+	
G	Brake-	
H	-	
L	-	See Below*

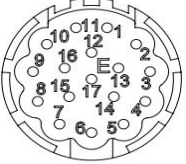
Feedback Connector Pin-Out		Pin Side View
Pin Number	Signal	
1	A(+)	
2	A(-)	
3	B(+)	
4	B(-)	
5	I(+)	
6	I(-)	
7	-	
8	-	
9	EPWR 5V	
10	Common	
11	-	
12	-	
13	Therm Switch	
14	Therm Switch	
15	S1	
16	S2	
17	S3	
Actuator Case	-	

Mfg's Cable Part Number-
2090-CFBM7DF-CDAxyy

*GTX060 & GTX080:
2090-CPBM7DF-16Axyy
GTX100: 2090-CPBM7DF-
14Axyy

Rockwell Automation -SICK (RA-S1C2) - Hiperface, SKM36 multi-turn absolute encoder. MPL Type V feedback (128 sin/cos) /M23 connectors!

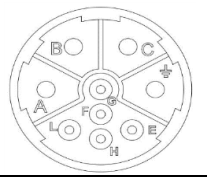
Power Connector Pin-Out		Pin Side View
Pin Number	Signal	
A	Phase U	
B	Phase V	
C	Phase W	
D	Ground	
E	-	
F	Brake+	
G	Brake-	
H	-	
L	-	

See Below*

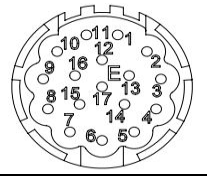
Feedback Connector Pin-Out		Pin Side View
Pin Number	Signal	
1	Sine +	
2	Sine -	
3	Cos +	
4	Cos -	
5	Data +	
6	Data -	
7	-	
8	-	
9	-	
10	ECOM	
11	+ 9 vdc	
12	-	
13	Therm Switch	
14	Therm Switch	
15	-	
16	-	
17	-	
Actuator Case	-	

Mfg's Cable Part Number-2090-CFBM7DF-CDAXxy

1. Not compatible with Kinetix 300 Drives.

Rockwell Automation - SICK Absolute DSL Encoder (RA-S3C0) - Hiperface, EKM36 multi-turn absolute encoder w/M23 connectors

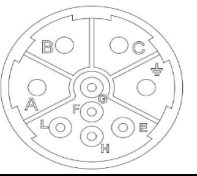
Power Connector Pin-Out		Pin Side View
Pin Number	Signal	
A	Phase U	
B	Phase V	
C	Phase W	
D	Ground	
E	Data +	
F	Brake+	
G	Brake-	
L	-	

Mfg's Cable Part Number-2090-CSBM1DE-14AA05

Siemens-Resolver (SM-R1B1) - Standard Resolver – 1FK7 motor wiring w/M23 connectors

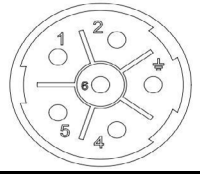
Power Connector Pin-Out		Pin Side View
Pin Number	Signal	
1	U	
2	V	
3	GNYE	
4	BD1+	
5	BD2-	
6	W	

See Below*

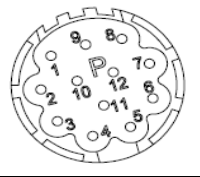
Feedback Connector Pin-Out		Pin Side View
Pin Number	Signal	
1	SIN	
2	*SIN	
3	-	
4	-	
5	-	
6	Shield	
7	-Vpp	
8	PT1000	
9	PT1000	
10	+Vpp	
11	COS	
12	*COS	
Actuator Case	Shield	

Mfg's Cable Part Number-6FX5002-2CF02-...

*GTX060 & GTX080:
6FX5002-5DA01-...
GTX100: 6FX5002-5DA11-....

Siemens-Heidenhain (SM-H1B2) - EnDat 2.1 Heidenhain EQN1125 multi-turn absolute encoder – 1FK7 motor wiring w/M23 connectors

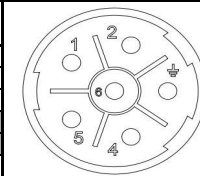
Power Connector Pin-Out		Pin Side View
Pin Number	Signal	
1	U	
2	V	
3	GNYE	
4	BD1+	
5	BD2-	
6	W	

See Below*

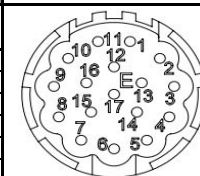
Feedback Connector Pin-Out		Pin Side View
Pin Number	Signal	
1	A+	
2	A-	
3	+ data	
4	-	
5	+clock	
6	-	
7	M-Encoder	
8	PT1000	
9	PT1000	
10	P-Encoder	
11	B+	
12	B-	
13	- data	
14	-clock	
15	0 V Sense	
16	5 V Sense	
17	-	
Actuator Case	-	

Mfg's Cable Part Number-6FX.002-2DC36-....

*GTX060 & GTX080: 6FX5002-5DA01-...
GTX100: 6FX5002-5DA11-....

Stober-Resolver (SB-R4A1) - Standard Resolver ED/EK motor wiring w/ M23 connector

Power Connector Pin-Out		Pin Side View
Pin Number	Signal	
1	U	
2	GND	
3	V	
4	W	
A	Brake	
B	Brake	
C	Therm Switch	
D	Therm Switch	

Feedback Connector Pin-Out		Pin Side View
Pin Number	Signal	
1	Sin + (S4)	
2	Sin - (S2)	
3	Cos + (S3)	
4	Cos - (S1)	
5	-	
6	-	
7	Erreg+ (R2)	
8	Erreg- (R1)	
9	-	
10	-	
11	-	
12	-	
Actuator Case	-	

Stober-Heidenhain (SB-H1A1) - EnDat 2.1 Heidenhain EQN1125 multi-turn absolute encoder – ED/EK motor wiring w/M23 connectors

Power Connector Pin-Out		Pin Side View
Pin Number	Signal	
1	U	
2	GND	
3	S	
4	T	
A	Brake	
B	Brake	
C	Therm Switch	
D	Therm Switch	

Feedback Connector Pin-Out		Pin Side View
Pin Number	Signal	
1	Clock +	
2	Up Sense	
3	-	
4	-	
5	Data -	
6	Data	
7	-	
8	Clock -	
9	-	
10	0V	
11	-	
12	Up	
Actuator Case	-	

Mfg's Cable Part Number-
Stober Absolute Encoder
Cable

Exlar GTX Actuator Ordering Information

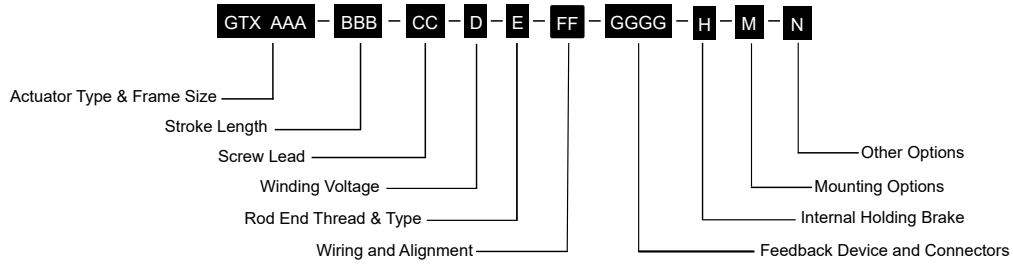

AAA = Exlar GTX Integrated Motor / Actuator
 060 = 60 mm (2.36 in)
 080 = 80 mm (3.15 in)
 100 = 100 mm (3.94)

BBB = Exlar GTX Standard Stroke Length¹

	060	080	100
80	-	-	-
-	100	-	-
150	150	150	150
300	300	300	300
-	450	-	-

CC = Roller Screw Lead

01 = 2.54 mm (0.1 in)
 02 = 5.08 mm (0.2 in)
 04 = 10.2 mm (0.4 in), (GTX060)
 05 = 12.7 mm (0.5 in), (GTX080, GTX100)

D = Winding Voltage

4 = 460 VAC Max
 D = 48 VDC Max (GTX060, GTX080)

E = Rod End Thread & Type

A = Male Metric
 B = Female Metric
 C = Male Metric, Splined²
 D = Female Metric, Splined²
 F = Female Standard
 G = Male Standard, Splined²
 H = Female Standard, Splined²
 L = Female Metric, 17-4 Stainless Steel
 M = Male Standard
 R = Male Metric, 17-4 Stainless Steel
 V = Female Standard, 17-4 Stainless Steel
 W = Male Standard, 17-4 Stainless Steel

FF = Wiring and Alignment

See table on next page

GGGG = Feedback Device and Connectors

See table on next page

H = Internal Holding Brake

N = No Brake
 B = Internal Holding Brake, Electronically Released

M = Mounting Options

N = None
 1 = Front Flange, Metric
 3 = Tapped Face, Metric
 5 = Rear Clevis, Metric
 F = Front Flange, Standard
 C = Rear Clevis, Standard

N = Other Options

N = None
 A = Anti-Rotate Assembly, External
 L = Limit Switch Housing/ Anti-Rotate Assembly³

NOTES:

- ¹ Non-standard stroke lengths available in 25 mm increments. Extended lead-times may apply
- ² Splined Rod (Internal Anti-Rotate) option reduces IP rating.
- ³ Switches sold separately



For Exlar GTX options or specials not listed above, please contact:
cha_applications@curtisswright.com

Drive / Feedback Designator Callouts

Drive Manufacturers	Wiring & Alignment Code	Resolver	Incremental Encoder	SICK Hiperface Absolute Encoder	SICK Hiperface DSL Absolute Encoder	Heidenhain Endat 2.1 Absolute Encoder ¹	Heidenhain Endat 2.2 Absolute Encoder ²
AMK	AK	R1A1				H1A1	
B&R Automation	BR	R1A1				H1A2	H3A8 ³
Baldor	BD	R1A1				H1A1	
Baumuller	BM	R1A1		S1A1		H1A2	
Beckhoff Automation	BE				S4C0 ³	H1A2	H3C2 ³
Control Techniques / Nidec	CT	R2B1	E1B2	S1B1		H1B2	
Elau / Schneider	EU			S1A1 ⁴			
Elmo Motion Control	EL	R1B1	E1B2			H1B2	
Curtiss-Wright Exlar	EX	R1A1	E1A2	S1A2		H1A2	
Infranor	IF	R1B2		S1B2			
Bosch-Rexroth	IN			S2D3 ⁴		H1D3	
Kollmorgen	KM	R2A1	E1A2			H1A2	
LTI	LS	R2A1		S1A2			
Lenze	LZ	R1B1		S1B1			
Parker	PC	R1B1	E1B2			H1B2	
Rockwell Automation	RA		E1C2	S1C2 ⁴	S3C0 ⁴		
Siemens	SM	R1B1				H1B2	
Stober Drives	SB	R4A1				H1A1	

¹Synchronous serial EnDat 2.1 with 1 Vpp Incremental Signals (EnDat01)

²Synchronous serial EnDat 2.2 without Incremental Signals (EnDat22)

³Supports Functional Safety

⁴Encoder is pre-programmed for operation with the manufacturer's servo drives.

Warranty and Limitations of Liability

Please see our warranty on our website here: <https://www.cw-actuation.com/en-gb/about/terms-conditions> for details.



SENSORS & ACTUATION

18400 W. 77th Street
Chanhassen, MN 55317

T: (+1) 952.500.6200

E: cha_applications@curtisswright.com

W: actuation.curtisswright.com