

**CURTISS -  
WRIGHT**



---

# Exlar<sup>®</sup> FTX Catalog

High-Force Electric Actuator



## Table of Contents

<b>Exlar FTX High-Force Electric Actuators, the Perfect Hydraulic Actuator Replacement</b> .....	3	<b>Performance to Stroke</b> .....	18
Hydraulic Cylinder Replacement .....	3	<b>Estimated Service Life</b> .....	18
Rugged and Reliable .....	3	Service Life Estimate Assumptions.....	18
Minimal Maintenance.....	3	<b>Dimensions</b> .....	19
<b>Four Frame Sizes</b> .....	4	Exlar FTX095.....	19
<b>Product Features</b> .....	5	Exlar FTX125.....	21
Configure Options Online with our 3D Model Builder.....	6	Exlar FTX160.....	23
Flexible Motor or Gearbox Mounting Options.....	6	Exlar FTX215.....	25
Flexible Mounting Options .....	7	Rod Eye, Spherical.....	27
Easy Maintenance & Installation .....	8	Case Dimensions .....	27
Multiple Lubrication Options .....	8	Rod Clevis.....	27
<b>Mechanical Specifications</b> .....	9	<b>Exlar FTX Exploded View</b> .....	28
Exlar FTX095.....	9	<b>Exlar FTX Actuator Ordering Information</b> .....	29
Standard Motor/Gearbox Mount Codes .....	10	Exlar FTX Accessories .....	30
Exlar FTX125.....	11	<b>Warranty and Limitations of Liability</b> .....	30
Standard Motor/Gearbox Mount Codes .....	12		
Exlar FTX160.....	14		
Standard Motor/Gearbox Mount Codes .....	15		
Exlar FTX215.....	16		
Standard Motor/Gearbox Mount Codes .....	17		

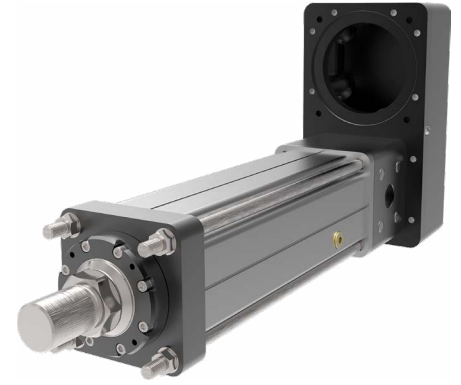

## Exlar<sup>®</sup> FTX

### The Perfect Hydraulic Actuator Replacement

#### Key Features

- Durable roller screw for extended life
- Minimal maintenance
- Rugged and reliable

#### Applications

- Automotive
  - Lift station, automated assembly, riveting, fastening, and joining
- Food Processing
  - Packaging machinery and pick and place systems
- Machining
  - Automated flexible fixturing, machine tooling, parts clamping, and precision grinders
- Entertainment / Simulation
  - Motion simulators and ride automation
- Process Control
  - Conveyor diverters / gates, precision valve control, and tension control
- Plastics
  - Cut-offs, die cutters, molding, and formers
- Material Handling
  - Stamping, indexing stages, product sorting, material cutting, web guidance, wire winding, pressing, and tube bending

## Exlar FTX High-Force Electric Actuators, the Perfect Hydraulic Actuator Replacement

### Hydraulic Cylinder Replacement

Hydraulic cylinders provide long life and high force in a small package. When replacing hydraulic actuators with electric, roller screws are a superior alternative to ball screws. The Exlar FTX high force electric actuators were designed specifically to allow easy migration from traditional hydraulic actuation to electric.

- Based on planetary roller screw technology, the Exlar FTX offers 15X the life and 2X the force density, not attainable with more common ball screw based electric actuators, making the Exlar FTX the right choice when migrating from hydraulic to electric actuation.

### Rugged and Reliable

Hydraulic cylinders are commonly installed in harsh industrial settings. Therefore, all Exlar FTX models are environmentally sealed to IP65S. In addition, its planetary roller screw mechanism withstands significantly higher shock loads than weaker ball screw alternatives. Migrate to electric with confidence knowing the Exlar FTX is every bit as rugged and reliable as the hydraulics they are designed to replace.

### Minimal Maintenance

More and more machine builders are looking to eliminate the mess and downtime associated with hydraulic fluid leaks. Electric actuation not only eliminates the problems associated with fluid leaks, it offers significantly higher levels of performance and flexibility than is possible even with servo-hydraulic solutions. Exlar FTX roller screw actuators allow machine builders to meet the ever-increasing performance demands of their customers while minimizing or eliminating the maintenance issues associated with traditional hydraulic solutions.

Four Frame Sizes Spanning from 95 mm to 215 mm

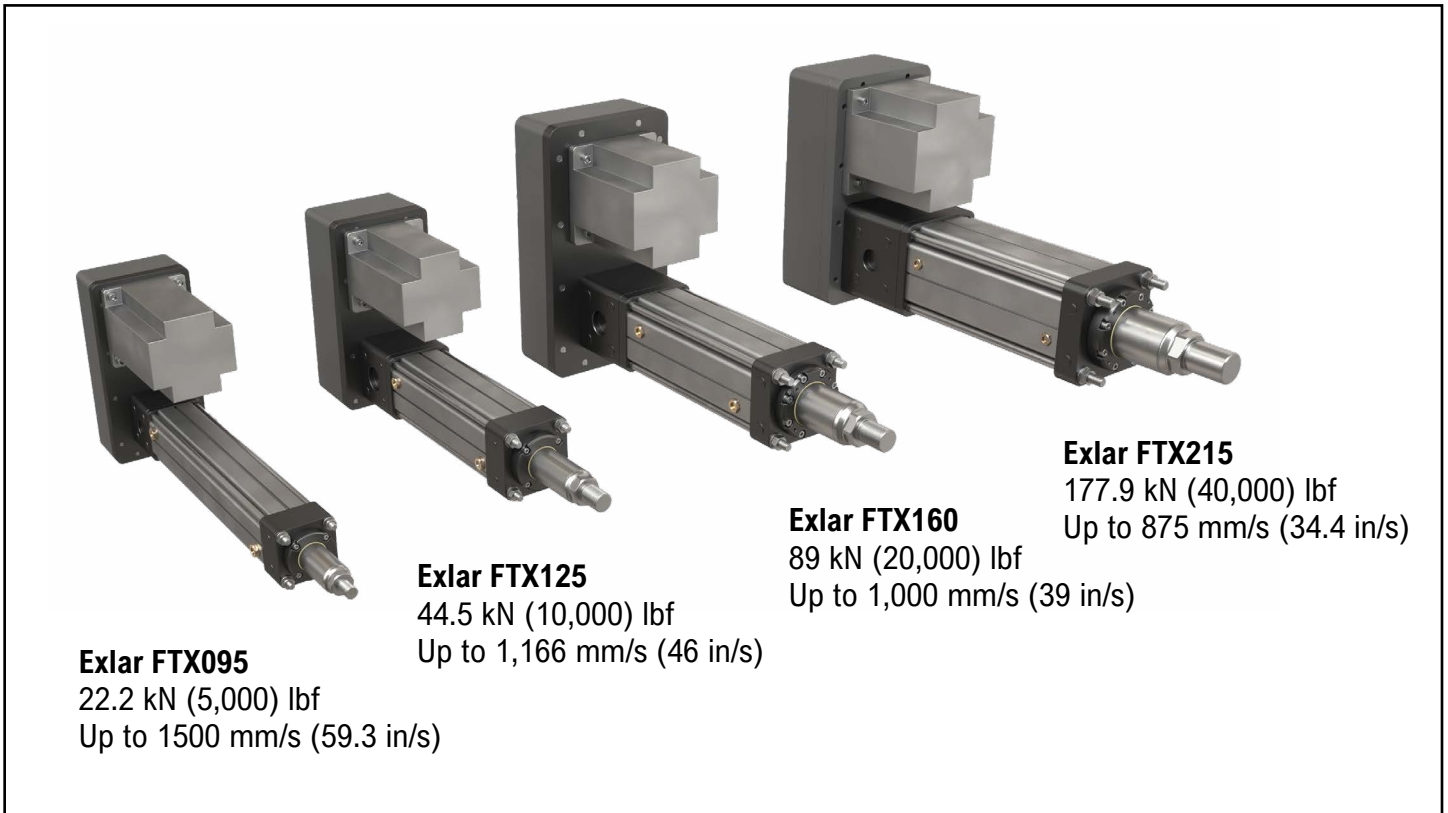

Figure 1: Four Frame Sizes

## Product Features

The Exlar FTX actuators are designed with features that deliver exceptional reliability and life with 100% duty cycle, enabling continuous operation without downtime. The robust design ensures durability and high performance in demanding environments. Low maintenance requirements reduce operational costs and simplify upkeep. These features make it ideal for heavy-duty industrial applications.



Figure 2: Product Features

## Configure Options Online with our 3D Model Builder

You can easily configure and download a model from our [3D model builder](#), available on our website in the product pages.

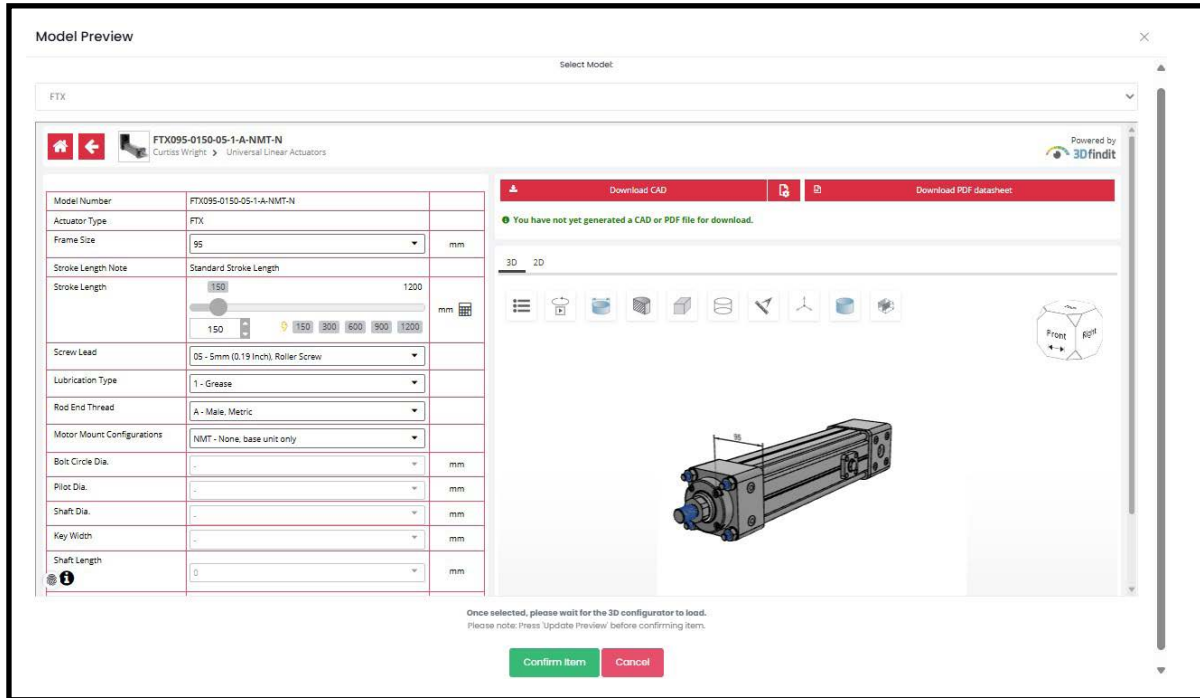
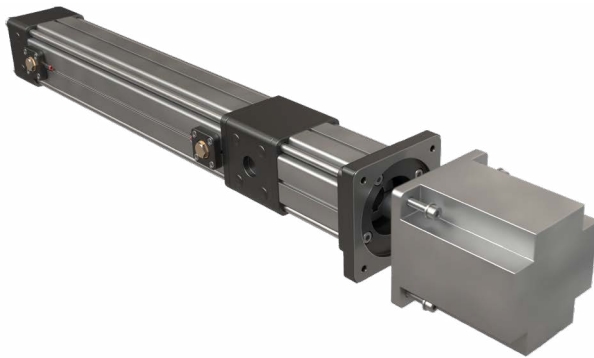

Figure 3: 3D Model Configurator

## Flexible Motor or Gearbox Mounting Options

Wide range of motor mounts — inline or parallel — for the most common servo motor and gearheads



### Inline

Easy motor installation with no key required

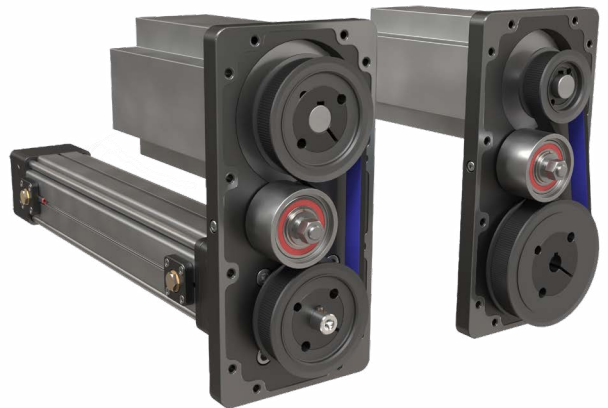

### Parallel 1:1

Parallel mounting offered in 1:1 or 2:1

### Parallel 2:1

## Flexible Mounting Options

Enables seamless integration into diverse applications, enhancing installation versatility and alignment precision; robust designs ensure stability under high loads, extending actuator life with minimal maintenance.

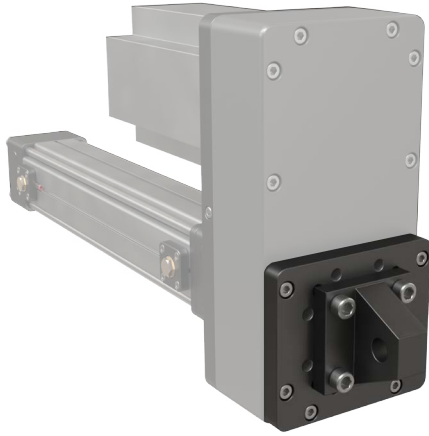

**Rear Eye**



**Rear Trunion**

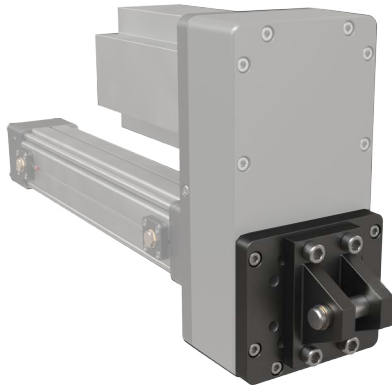

**Rear Clevis**

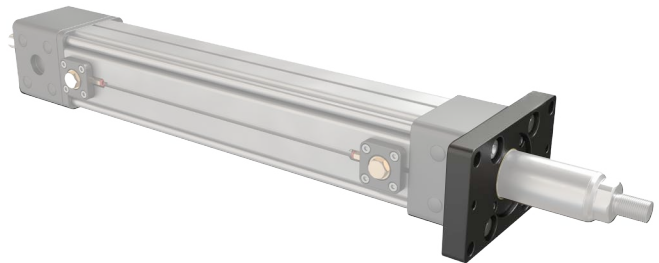

**Front Flange**

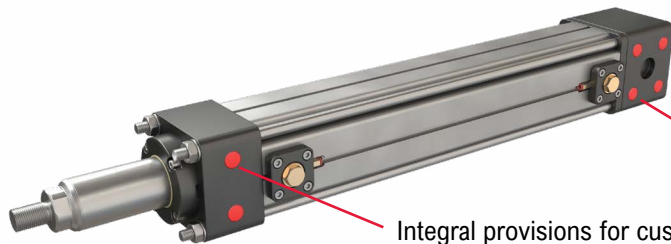

Integral provisions for customer designed mounting empowers users to tailor the actuator to the unique system requirements, increasing compatibility with specialized setups and enhancing design flexibility

## Easy Maintenance & Installation

Innovative idler pulley tensioning system: simplifies belt tension adjustment with a hex wrench, ensuring precise repeatable tensioning for optimal performance enhances reliability and reduces maintenance time compared to t-slot base tensioning motor mount adjustments.

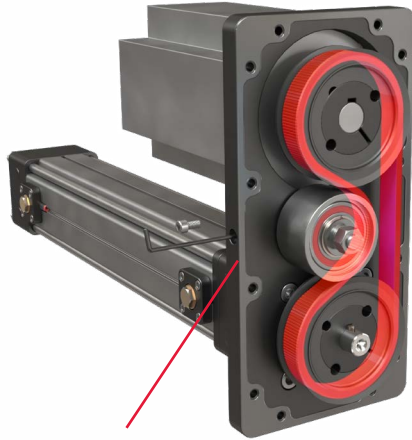

**Easy to Adjust Belt Tensioning**

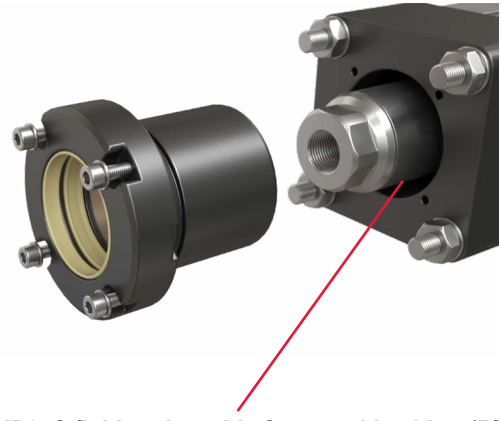

**IP65S field replaceable front seal bushing (FSB)** kit to easily replace the seal, scrapper, and main rod bearing with four accessible bolts. Kit ships as an assembly to reduce maintenance time.

## Multiple Lubrication Options

- Easily accessible ports for maintenance and inspections
- Regrease point directly to roller screw nut for grease-filled units
- Low-temperature grease options suitable down to -40 °C

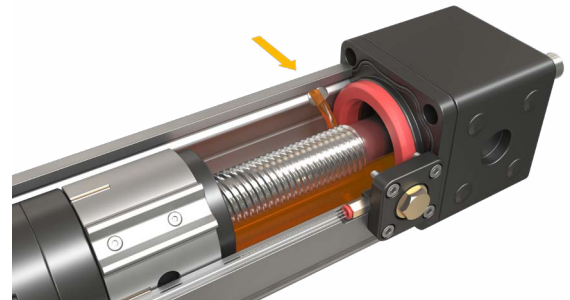

# Mechanical Specifications

## Exlar FTX095

		05	10	20
Screw Lead	mm	5	10	20
	in	0.197	0.394	0.787
Maximum Force	kN	22.2	22.2	22.2
	lbf	5,000	5,000	5,000
Life at Maximum Force	km	392	626	1440
	in x 10 <sup>6</sup>	15.4	24.6	56.7
C <sub>s</sub> (Dynamic Load Rating)	kN	95.2	88.3	92.5
	lbf	21,400	19,850	20,800
Maximum Input Torque	Nm	22.1	44.3	88.5
	lbf-in	196	392	783
Max Rated rpm @ Input Shaft	rpm	4,500	4,500	4,500
Maximum Linear Speed @ Maximum Rated rpm	mm/s	373	750	1,500
	in/s	14.7	29.5	59.3
Friction Torque (Typical)	Nm	1.12	1.12	1.12
	lbf-in	10	10	10

Weights kg (lbs)		
Base Actuator Weight (Zero Stroke)	kg	10
	lb	21
Actuator Weight Adder (Per 25 mm of stroke)	kg	0.39
	lb	0.87
Adder for Inline (excluding motor)	kg	2.9
	lb	6.5
Adder for Parallel Drive (excluding motor)	kg	13.1
	lb	28.9
Adder for Front Flange	kg	1.9
	lb	4.2
Adder for Rear Clevis	kg	5.3
	lb	11.7
Adder for Rear Eye	kg	5.1
	lb	11.3
Adder for Rear Trunnion	kg	1.9
	lb	4.3

Operating Conditions and Usage		
<b>Accuracy:</b>		
Screw Travel Variation	mm (in)	0.030 (0.0012)
Screw Lead Error	mm/300 mm (in/ft)	0.025 (0.001)
Screw Lead Backlash	mm (in)	0.060 (0.002)
<b>Ambient Conditions:</b>		
Standard Ambient Temperature	°C	0 to 85
Low Temperature Grease Option		-40
IP Rating		IP65S

Long Stroke Dynamic Load Rating (C <sub>s</sub> )				
<b>Exlar FTX095</b>		<b>05</b>	<b>10</b>	<b>20</b>
*C <sub>s</sub> (Dynamic Load Rating) Greater than 900 mm Stroke	kN	95.2	88.3	92.5
	lbf	21,400	19,850	20,800

Actuator Inertia			
Base Unit Inertia		Zero Stroke [kg-m <sup>2</sup> (lbf-in-sec <sup>2</sup> )]	Add per 25 mm [kg-m <sup>2</sup> (lbf-in-sec <sup>2</sup> )]
5 mm Lead		8.27 x 10 <sup>-4</sup> (7.32 x 10 <sup>-3</sup> )	2.19 x 10 <sup>-6</sup> (1.94 x 10 <sup>-5</sup> )
10 mm Lead		8.33 x 10 <sup>-4</sup> (7.37 x 10 <sup>-3</sup> )	2.42 x 10 <sup>-6</sup> (2.14 x 10 <sup>-5</sup> )
20 mm Lead		8.57 x 10 <sup>-4</sup> (7.58 x 10 <sup>-3</sup> )	3.31 x 10 <sup>-6</sup> (2.93 x 10 <sup>-5</sup> )
Inline Drive Inertia	Inline Unit - w/Motor Coupling	Inline Unit - w/Motor Coupling - For Gearbox Mount	Add per 25 mm
5 mm Lead	9.27 x 10 <sup>-4</sup> (8.20 x 10 <sup>-3</sup> )	1.09 x 10 <sup>-3</sup> (9.62 x 10 <sup>-3</sup> )	2.19 x 10 <sup>-6</sup> (1.94 x 10 <sup>-5</sup> )
10 mm Lead	9.33 x 10 <sup>-4</sup> (8.26 x 10 <sup>-3</sup> )	1.09 x 10 <sup>-3</sup> (9.67 x 10 <sup>-3</sup> )	2.42 x 10 <sup>-6</sup> (2.14 x 10 <sup>-5</sup> )
20 mm Lead	9.57 x 10 <sup>-4</sup> (8.47 x 10 <sup>-3</sup> )	1.12 x 10 <sup>-3</sup> (9.89 x 10 <sup>-3</sup> )	3.31 x 10 <sup>-6</sup> (2.93 x 10 <sup>-5</sup> )
Parallel Drive Inertia		1:1 Reduction	2:1 Reduction
5 mm Lead (zero stroke)		4.90 x 10 <sup>-3</sup> (4.34 x 10 <sup>-2</sup> )	2.22 x 10 <sup>-3</sup> (1.97 x 10 <sup>-2</sup> )
Add per 25 mm stroke		2.19 x 10 <sup>-6</sup> (1.94 x 10 <sup>-5</sup> )	5.48 x 10 <sup>-7</sup> (4.85 x 10 <sup>-6</sup> )
10 mm Lead (zero stroke)		4.91 x 10 <sup>-3</sup> (4.34 x 10 <sup>-2</sup> )	2.23 x 10 <sup>-3</sup> (1.97 x 10 <sup>-2</sup> )
Add per 25 mm stroke		2.42 x 10 <sup>-6</sup> (2.14 x 10 <sup>-5</sup> )	6.04 x 10 <sup>-7</sup> (5.34 x 10 <sup>-6</sup> )
20 mm Lead (zero stroke)		4.93 x 10 <sup>-3</sup> (4.37 x 10 <sup>-2</sup> )	2.23 x 10 <sup>-3</sup> (1.98 x 10 <sup>-2</sup> )
Add per 25 mm stroke		3.31 x 10 <sup>-6</sup> (2.93 x 10 <sup>-5</sup> )	8.28 x 10 <sup>-7</sup> (7.33 x 10 <sup>-6</sup> )

Standard Motor/Gearbox Mount Codes for the Exlar FTX095

Exlar FTX095 Motor / Gearbox Mounts																
None		Inline					Parallel 1:1					Parallel 2:1				
		Dimension in mm					Dimension in mm					Dimension in mm				
Motor Flange Code	Motor Flange Code	Bolt Circle	Pilot Diam.	Min. Shaft Length		Motor Flange Code	Bolt Circle	Pilot Diam.	Min. Shaft Length		Motor Flange Code	Bolt Circle	Pilot Diam.	Min. Shaft Length		
NMT-	00	N10-	02	68	60	30	P10-	02	68	60	46	P20-	02	68	60	44
		N10-	04	75	60	30	P10-	04	75	60	46	P20-	04	75	60	44
		N10-	05	85	70	37	P10-	05	85	70	46	P20-	05	85	70	44
		N10-	10	100	80	30	P10-	10	100	80	35	P20-	10	100	80	37
		N10-	11	115	95	30	P10-	11	115	95	39	P20-	11	115	95	37
		N10-	12	130	110	30	P10-	12	130	110	46	P20-	12	130	110	44
		N10-	13	130	95	30	P10-	13	130	95	46	P20-	13	130	95	44
		N10-	14	145	110	30	P10-	14	145	110	46	P20-	14	145	110	44
		N10-	19	165	130	30	P10-	19	165	130	46	P20-	19	165	130	44
Motor Shaft Code	Motor Shaft Code	Shaft Diam.	Key Width*			Motor Shaft Code	Shaft Diam.	Key Width*			Motor Shaft Code	Shaft Diam.	Key Width*			
00	AA	24	8			AA	24	8			AA	24	8			
	BA	22	6			BA	22	6			BA	22	6			
	CA	22	8			CA	22	8			CA	22	8			
	DA	20	6			DA	20	6			DA	20	6			
	EA	19	6			EA	19	6			EA	19	6			
	FA	16	5			FA	16	5			FA	16	5			
	GA	14	5			GA	14	5			GA	14	5			
	LA	28	8			LA	28	8			LA	28	8			
	MA	32	10			MA	32	10								
Shaft Length	Shaft Length					Shaft Length					Shaft Length					
000	030, 032, 037, 040, 048, 050, 055, 058, 060, 063, 065, 070, 080	Pick closest shaft length within 2 mm if your exact length is not listed				035-084	Allowable shaft length range in 1 mm increments				037-084	Allowable shaft length range in 1 mm increments				

\*Key not required for operation

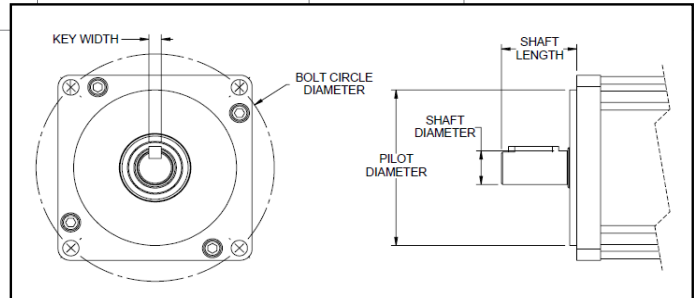

NOTE: Motor/gearbox key not required to interface with Exlar FTX Series actuators

Exlar FTX125

		05	10	20
Screw Lead	mm	5	10	20
	in	0.197	0.394	0.787
Maximum Force	kN	44.5	44.5	44.5
	lbf	10,000	10,000	10,000
Life at Maximum Force	km	249.2	486.3	719.6
	in x 10 <sup>6</sup>	9.81	19.14	28.33
C <sub>s</sub> (Dynamic Load Rating)	kN	163.7	162.4	146.9
	lbf	36,800	36,500	33,014
Maximum Input Torque	Nm	46.5	82.3	177.0
	lbf-in	412	728	1,566
Max Rated rpm @ Input Shaft	rpm	3,500	3,500	3,500
Maximum Linear Speed @ Maximum Rated rpm	mm/s	292	583	1,166
	in/s	11.5	23	46
Friction Torque (Typical)	Nm	2.23	2.23	2.23
	lbf-in	20	20	20

Weights kg (lbs)		
Base Actuator Weight (Zero Stroke)	kg	21
	lb	47
Actuator Weight Adder (Per 25 mm of stroke)	kg	0.84
	lb	1.85
Adder for Inline (excluding motor)	kg	6.8
	lb	15.0
Adder for Parallel Drive (excluding motor)	kg	25.6
	lb	56.5
Adder for Front Flange	kg	3.6
	lb	7.9
Adder for Rear Clevis	kg	6.5
	lb	14.3
Adder for Rear Eye	kg	6.3
	lb	13.8
Adder for Rear Trunnion	kg	3.1
	lb	6.8

Operating Conditions and Usage		
<b>Accuracy:</b>		
Screw Travel Variation	mm (in)	0.030 (0.0012)
Screw Lead Error	mm/300 mm (in/ft)	0.025 (0.001)
Screw Lead Backlash	mm (in)	0.060 (0.002)
<b>Ambient Conditions:</b>		
Standard Ambient Temperature	°C	0 to 85
Low Temperature Grease Option		-40
IP Rating		IP65S

Long Stroke Dynamic Load Rating (C <sub>s</sub> )				
<b>Exlar FTX125</b>		<b>05</b>	<b>10</b>	<b>20</b>
*C <sub>s</sub> (Dynamic Load Rating) Greater than 900 mm Stroke	kN	143.4	162.4	146.9
	lbf	32,240	36,500	33,014

Actuator Inertia			
Base Unit Inertia	Zero Stroke [kg·m <sup>2</sup> (lbf-in·sec <sup>2</sup> )]		Add per 25 mm [kg·m <sup>2</sup> (lbf-in·sec <sup>2</sup> )]
5 mm Lead	2.55 x 10 <sup>-3</sup> (2.26 x 10 <sup>-2</sup> )		4.62 x 10 <sup>-5</sup> (4.09 x 10 <sup>-4</sup> )
10 mm Lead	2.56 x 10 <sup>-3</sup> (2.27 x 10 <sup>-2</sup> )		4.65 x 10 <sup>-5</sup> (4.12 x 10 <sup>-4</sup> )
20 mm Lead	2.61 x 10 <sup>-3</sup> (2.31 x 10 <sup>-2</sup> )		4.81 x 10 <sup>-5</sup> (4.26 x 10 <sup>-4</sup> )
Inline Drive Inertia	< 32 mm Motor - Shaft Diameter	> 32 mm Motor - Shaft Diameter	Add per 25 mm
5 mm Lead	2.81 x 10 <sup>-3</sup> (2.49 x 10 <sup>-2</sup> )	3.35 x 10 <sup>-3</sup> (2.97 x 10 <sup>-2</sup> )	4.62 x 10 <sup>-5</sup> (4.09 x 10 <sup>-4</sup> )
10 mm Lead	2.82 x 10 <sup>-3</sup> (2.50 x 10 <sup>-2</sup> )	3.36 x 10 <sup>-3</sup> (2.98 x 10 <sup>-2</sup> )	4.65 x 10 <sup>-5</sup> (4.12 x 10 <sup>-4</sup> )
20 mm Lead	2.87 x 10 <sup>-3</sup> (2.54 x 10 <sup>-2</sup> )	3.41 x 10 <sup>-3</sup> (3.02 x 10 <sup>-2</sup> )	4.81 x 10 <sup>-5</sup> (4.26 x 10 <sup>-4</sup> )
Parallel Drive Inertia	1:1 Reduction		2:1 Reduction
5 mm Lead (zero stroke)	9.43 x 10 <sup>-3</sup> (8.34 x 10 <sup>-2</sup> )		4.66 x 10 <sup>-3</sup> (4.12 x 10 <sup>-2</sup> )
Add per 25 mm stroke	4.62 x 10 <sup>-5</sup> (4.09 x 10 <sup>-4</sup> )		1.15 x 10 <sup>-5</sup> (1.02 x 10 <sup>-4</sup> )
10 mm Lead (zero stroke)	9.44 x 10 <sup>-3</sup> (8.35 x 10 <sup>-2</sup> )		4.66 x 10 <sup>-3</sup> (4.13 x 10 <sup>-2</sup> )
Add per 25 mm stroke	4.65 x 10 <sup>-5</sup> (4.12 x 10 <sup>-4</sup> )		1.16 x 10 <sup>-5</sup> (1.03 x 10 <sup>-4</sup> )
20 mm Lead (zero stroke)	9.49 x 10 <sup>-3</sup> (8.39 x 10 <sup>-2</sup> )		4.81 x 10 <sup>-3</sup> (4.26 x 10 <sup>-2</sup> )
Add per 25 mm stroke	4.67 x 10 <sup>-5</sup> (4.14 x 10 <sup>-4</sup> )		1.20 x 10 <sup>-5</sup> (1.06 x 10 <sup>-4</sup> )

Standard Motor/Gearbox Mount Codes for the Exlar FTX125

Exlar FTX125 Motor / Gearbox Mounts											
None		Inline				Parallel 1:1					
		Dimension in mm				Dimension in mm					
Motor Flange Code		Motor Flange Code		Bolt Circle	Pilot Diam.	Motor Flange Code		Bolt Circle	Pilot Diam.	Min. Shaft Length	
NMT-	00	N10-	05	85	70	P10-	05	85	70	50	
		N10-	10	100	80	P10-	10	100	80	50	
		N10-	12	130	110	P10-	12	130	110	55	
		N10-	14	145	110	P10-	14	145	110	55	
		N10-	18	120	90	P10-	18	120	90	55	
		N10-	19	165	130	P10-	19	165	130	55	
		N10-	20	200	114.3	P10-	20	200	114.3	55	
		N10-	21	215	130	P10-	21	215	130	55	
		N10-	23	215	180	P10-	23	215	180	65	
Motor Shaft	Motor Shaft Code	Shaft Diam.	Key Width*	Min. Shaft Length	Motor Shaft Code	Shaft Diam.	Key Width*				
00	AA	24	8	40	AA	24	8				
	AB	28	10	40	AB	28	10				
	BA	22	6	40	BA	22	6				
	DA	20	6	40	DA	20	6				
	EA	19	6	40	EA	19	6				
	LA	28	8	40	LA	28	8				
	MA	32	10	40	MA	32	10				
	NA	35	10	40	NA	35	10				
	PA	38	10	80	PA	38	10				
	RA	42	12	80	RA	42	12				
	SA	42	10	80	SA	42	10				
	YA	24	10	40	YA	24	10				
Shaft Length	Shaft Length			Shaft Length			Shaft Length				
000	040, 046, 049, 050, 055, 058, 060, 063, 065, 068, 072, 080, 082, 088, 097, 100, 102, 105, 112, 113			Pick closest shaft length within 2 mm if your exact length is not listed			050-122			Allowable shaft length range in 1 mm increments	

\*Key not required for operation

Parallel 2:1

Motor Flange Code		Dimension in mm		Min shaft length - Per Motor Shaft Code									Motor Shaft Code	Shaft Diam.	Key Width*
		Bolt Circle	Pilot Diam.	AA	AB = LA	BA	DA	EA	LA	MA	NA	YA = AA			
P20-	05	85	70	45	59	42	42	45	59	59	59	45	AA	24	8
P20-	10	100	80	45	59	42	42	45	59	59	59	45	AB	28	10
P20-	12	130	110	38	52	35	35	38	52	52	52	38	BA	22	6
P20-	14	145	110	50	64	47	47	50	64	64	64	50	DA	20	6
P20-	19	165	130	50	64	47	47	50	64	64	64	50	EA	19	6
P20-	20	200	114.3	50	64	47	47	50	64	64	64	50	LA	28	8
P20-	21	215	130	50	64	47	47	50	64	64	64	50	MA	32	10
P20-	23	215	180	53	67	50	50	53	67	67	67	53	NA	35	10
P20-	23	215	180	53	67	50	50	53	67	67	67	53	YA	24	10

Shaft Length	
045-122	Allowable shaft length range in 1 mm increments

\*Key not required for operation

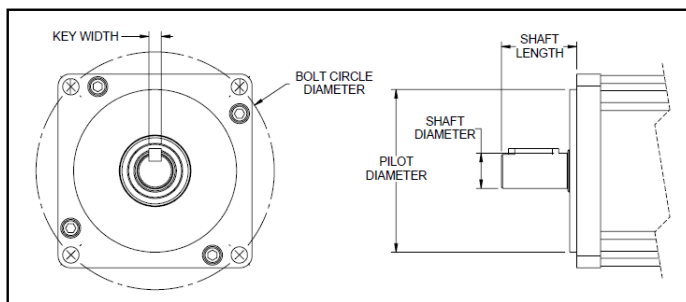

NOTE: Motor/gearbox key not required to interface with Exlar FTX Series actuators

Exlar FTX160

		06	12	30
Screw Lead	mm	6	12	30
	in	0.236	0.472	1.181
Maximum Force	kN	89.0	89.0	89.0
	lbf	20,000	20,000	20,000
Life at Maximum Force	km	154.9	416.6	358.9
	in x 10 <sup>6</sup>	6.1	16.4	21.2
C <sub>s</sub> (Dynamic Load Rating)	kN	263.7	290.0	233.0
	lbf	59,275	65,200	52,400
Maximum Input Torque	Nm	106	212	531
	lbf-in	940	1,880	4,699
Max Rated rpm @ Input Shaft	rpm	2,000	2,000	2,000
Maximum Linear Speed @ Maximum Rated rpm	mm/s	201	401	1000
	in/s	7.9	15.8	39.0
Friction Torque (Typical)	Nm	4.54	4.54	4.54
	lbf-in	40	40	40

Weights kg (lbs)			
Base Actuator Weight (Zero Stroke)	kg	49	
	lb	108	
Actuator Weight Adder (Per 25 mm of stroke)	kg	1.62	
	lb	3.6	
Adder for Inline (excluding motor)	kg	14.2	
	lb	31.5	
Adder for Parallel Drive (excluding motor)	kg	53.1	
	lb	117.8	
Adder for Front Flange	kg	7.4	
	lb	16.4	
Adder for Rear Clevis	kg	21.2	
	lb	48.8	
Adder for Rear Eye	kg	22.4	
	lb	49.7	
Adder for Rear Trunnion	kg	10.9	
	lb	24.2	

Operating Conditions and Usage		
<b>Accuracy:</b>		
Screw Travel Variation	mm (in)	0.030 (0.0012)
Screw Lead Error	mm/300 mm (in/ft)	0.025 (0.001)
Screw Lead Backlash	mm (in)	0.060 (0.002)
<b>Ambient Conditions:</b>		
Standard Ambient Temperature	°C	0 to 85
Low Temperature Grease Option		-40
IP Rating		IP65S

Long Stroke Dynamic Load Rating (C <sub>s</sub> )				
Exlar FTX160		06	12	30
*C <sub>s</sub> (Dynamic Load Rating) Greater than 900 mm Stroke	kN	223.6	261.2	233
	lbf	50,270	58,720	52,400

Actuator Inertia			
Base Unit Inertia	Zero Stroke [kg-m <sup>2</sup> (lbf-in-sec <sup>2</sup> )]		Add per 25 mm [kg-m <sup>2</sup> (lbf-in-sec <sup>2</sup> )]
6 mm Lead	1.35 x 10 <sup>-2</sup> (1.19 x 10 <sup>-1</sup> )		2.57 x 10 <sup>-4</sup> (2.27 x 10 <sup>-3</sup> )
12 mm Lead	1.35 x 10 <sup>-2</sup> (1.20 x 10 <sup>-1</sup> )		2.58 x 10 <sup>-4</sup> (2.28 x 10 <sup>-3</sup> )
30 mm Lead	1.38 x 10 <sup>-2</sup> (1.22 x 10 <sup>-1</sup> )		2.66 x 10 <sup>-4</sup> (2.36 x 10 <sup>-3</sup> )
Inline Drive Inertia	< 32 mm Motor - Shaft Diameter	> 32 mm Motor - Shaft Diameter	Add per 25 mm
6 mm Lead	1.47 x 10 <sup>-2</sup> (1.30 x 10 <sup>-1</sup> )	1.67 x 10 <sup>-2</sup> (1.48 x 10 <sup>-1</sup> )	2.57x 10 <sup>-4</sup> (2.27 x 10 <sup>-3</sup> )
12 mm Lead	1.47 x 10 <sup>-2</sup> (1.30 x 10 <sup>-1</sup> )	1.68 x 10 <sup>-2</sup> (1.49 x 10 <sup>-1</sup> )	2.58 x 10 <sup>-4</sup> (2.28 x 10 <sup>-3</sup> )
30 mm Lead	1.50 x 10 <sup>-2</sup> (1.33 x 10 <sup>-1</sup> )	1.71 x 10 <sup>-2</sup> (1.51 x 10 <sup>-1</sup> )	2.66 x 10 <sup>-4</sup> (2.36 x 10 <sup>-3</sup> )
Parallel Drive Inertia	1:1 Reduction		2:1 Reduction
6 mm Lead (zero stroke)	5.27 x 10 <sup>-2</sup> (4.67 x 10 <sup>-1</sup> )		2.30 x 10 <sup>-2</sup> (2.04 x 10 <sup>-1</sup> )
Add per 25 mm stroke	2.57 x 10 <sup>-4</sup> (2.27 x 10 <sup>-3</sup> )		6.42 x 10 <sup>-5</sup> (5.68 x 10 <sup>-4</sup> )
12 mm Lead (zero stroke)	5.28 x 10 <sup>-2</sup> (4.67 x 10 <sup>-1</sup> )		2.30 x 10 <sup>-2</sup> (2.04 x 10 <sup>-1</sup> )
Add per 25 mm stroke	2.58 x 10 <sup>-4</sup> (2.28 x 10 <sup>-3</sup> )		6.45 x 10 <sup>-5</sup> (5.71 x 10 <sup>-4</sup> )
30 mm Lead (zero stroke)	5.30 x 10 <sup>-2</sup> (4.69 x 10 <sup>-1</sup> )		2.31 x 10 <sup>-2</sup> (2.05 x 10 <sup>-1</sup> )
Add per 25 mm stroke	2.66 x 10 <sup>-4</sup> (2.36 x 10 <sup>-3</sup> )		6.66 x 10 <sup>-5</sup> (5.89 x 10 <sup>-4</sup> )

Standard Motor/Gearbox Mount Codes for the Exlar FTX160

Exlar FTX160 Motor / Gearbox Mounts																
None		Inline				Parallel 1:1					Parallel 2:1					
		Motor Flange Code		Dimension in mm		Motor Flange Code		Dimension in mm			Motor Flange Code		Dimension in mm			
Motor Flange Code	Motor Flange Code	Bolt Circle	Pilot Diam.	Motor Flange Code	Bolt Circle	Pilot Diam.	Min. Shaft Length	Motor Flange Code	Bolt Circle	Pilot Diam.	Min. Shaft Length	Motor Flange Code	Bolt Circle	Pilot Diam.	Min. Shaft Length	
NMT- 00	N10- 10	100	80	P10- 10	100	80	59	P20- 10	100	80	46					
	N10- 12	130	110	P10- 12	130	110	59	P20- 12	130	110	58					
	N10- 18	120	90	P10- 18	120	90	69	P20- 18	120	90	58					
	N10- 19	165	130	P10- 19	165	130	69	P20- 19	165	130	44					
	N10- 20	200	114.3	P10- 20	200	114.3	69	P20- 20	200	114.3	58					
	N10- 21	215	130	P10- 21	215	130	69	P20- 21	215	130	55					
	N10- 22	215	160	P10- 22	215	160	69	P20- 23	215	180	58					
	N10- 23	215	180	P10- 23	215	180	69	P20- 24	235	200	58					
	N10- 24	235	200	P10- 24	235	200	69	P20- 25	265	230	58					
	N10- 25	265	230	P10- 25	265	230	69									
Motor Shaft Code	Motor Shaft Code	Shaft Diam.	Key Width*	Min. Shaft Length	Motor Shaft Code	Shaft Diam.	Key Width*	Motor Shaft Code	Shaft Diam.	Key Width*	Motor Shaft Code	Shaft Diam.	Key Width*	Motor Shaft Code	Shaft Diam.	Key Width*
00	AA	24	8	48	AA	24	8	AA	24	8	AA	24	8	AA	24	8
	BA	22	6	48	BA	22	6	BA	22	6	BA	22	6	BA	22	6
	LA	28	8	48	LA	28	8	LA	28	8	LA	28	8	LA	28	8
	MA	32	10	48	MA	32	10	MA	32	10	MA	32	10	MA	32	10
	NA	35	10	48	NA	35	10	NA	35	10	NA	35	10	NA	35	10
	PA	38	10	80	PA	38	10	PA	38	10	PA	38	10	PA	38	10
	QA	40	12	80	QA	40	12	QA	40	12	QA	40	12	QA	40	12
	RA	42	12	80	RA	42	12	RA	42	12	RA	42	12	RA	42	12
	SA	42	10	80	SA	42	10	SA	42	10	SA	42	10	SA	42	10
	UA	55	16	80	UA	55	16	UA	55	16	UA	55	16	UA	55	16
	ZA	25	8	48	ZA	25	8	ZA	25	8	ZA	25	8	ZA	25	8
Shaft Length	Shaft Length	Shaft Length	Shaft Length	Shaft Length	Shaft Length	Shaft Length	Shaft Length	Shaft Length	Shaft Length	Shaft Length	Shaft Length	Shaft Length	Shaft Length	Shaft Length	Shaft Length	Shaft Length
000	048, 050, 055, 058, 060, 065, 070, 072, 080, 082, 085, 088, 097, 100, 105, 110, 112, 113, 116	Pick closest shaft length within 2 mm if your exact length is not listed	059-124	Allowable shaft length range in 1 mm increments	046-124	Allowable shaft length range in 1 mm increments										

\*Key not required for operation

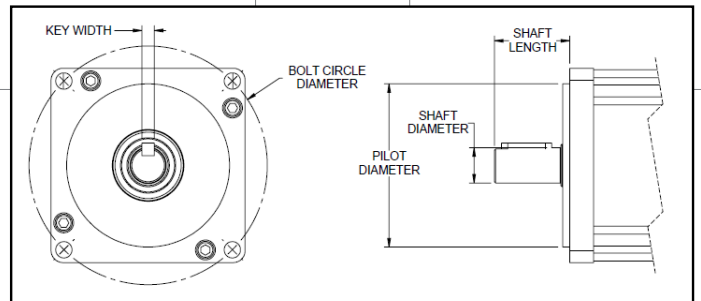

NOTE: Motor/gearbox key not required to interface with Exlar FTX Series actuators

Exlar FTX215

		06	12	30
Screw Lead	mm	6	12	30
	in	0.236	0.472	1.181
Maximum Force	kN	177.9	177.9	177.9
	lbf	40,000	40,000	40,000
Life at Maximum Force	km	78.7	161.8	414.3
	in x 10 <sup>6</sup>	3.1	6.4	16.3
C <sub>s</sub> (Dynamic Load Rating)	kN	398	423	376
	lbf	89,500	95,200	84,700
Maximum Input Torque	Nm	243	425	976
	lbf-in	2,148	3,760	8,642
Max Rated rpm @ Input Shaft	rpm	1,750	1,750	1,750
Maximum Linear Speed @ Maximum Rated rpm	mm/s	175	351	875
	in/s	6.9	13.8	34.4
Friction Torque (Typical)	Nm	5.65	5.65	5.65
	lbf-in	50	50	50

Weights kg (lbs)			
Base Actuator Weight (Zero Stroke)	kg	103	
	lb	227	
Actuator Weight Adder (Per 25 mm of stroke)	kg	2.70	
	lb	5.96	
Adder for Inline (excluding motor)	kg	38.6	
	lb	85.1	
Adder for Parallel Drive (excluding motor)	kg	62.3	
	lb	137.3	
Adder for Front Flange	kg	26.7	
	lb	58.8	
Adder for Rear Clevis	kg	32.5	
	lb	71.6	
Adder for Rear Eye	kg	32.5	
	lb	71.6	
Adder for Rear Trunnion	kg	9.6	
	lb	21.2	

Operating Conditions and Usage		
<b>Accuracy:</b>		
Screw Travel Variation	mm (in)	0.030 (0.0012)
Screw Lead Error	mm/300 mm (in/ft)	0.025 (0.001)
Screw Lead Backlash	mm (in)	0.060 (0.002)
<b>Ambient Conditions:</b>		
Standard Ambient Temperature	°C	0 to 85
Low Temperature Grease Option		-40
IP Rating		IP65S

Long Stroke Dynamic Load Rating (C <sub>s</sub> )				
Exlar FTX215		06	12	30
*C <sub>s</sub> (Dynamic Load Rating) Greater than 900 mm Stroke	kN	359.8	346.7	376
	lbf	80,900	77,950	84,700

Actuator Inertia			
Base Unit Inertia	Zero Stroke [kg-m <sup>2</sup> (lbf-in-sec <sup>2</sup> )]		Add per 25 mm [kg-m <sup>2</sup> (lbf-in-sec <sup>2</sup> )]
6 mm Lead	4.25 x 10 <sup>-2</sup> (3.76 x 10 <sup>-1</sup> )		8.00 x 10 <sup>-4</sup> (7.08 x 10 <sup>-3</sup> )
12 mm Lead	4.26 x 10 <sup>-2</sup> (3.77 x 10 <sup>-1</sup> )		8.02 x 10 <sup>-4</sup> (7.10 x 10 <sup>-3</sup> )
30 mm Lead	4.31 x 10 <sup>-2</sup> (3.82 x 10 <sup>-1</sup> )		8.15 x 10 <sup>-4</sup> (7.21 x 10 <sup>-3</sup> )
Inline Drive Inertia	< 55 mm Motor - Shaft Diameter	> 55 mm Motor - Shaft Diameter	Add per 25 mm
6 mm Lead	4.43 x 10 <sup>-2</sup> (3.92 x 10 <sup>-1</sup> )	6.15 x 10 <sup>-2</sup> (5.44 x 10 <sup>-1</sup> )	8.00 x 10 <sup>-4</sup> (7.08 x 10 <sup>-3</sup> )
12 mm Lead	4.44 x 10 <sup>-2</sup> (3.93 x 10 <sup>-1</sup> )	6.16 x 10 <sup>-2</sup> (5.45 x 10 <sup>-1</sup> )	8.02 x 10 <sup>-4</sup> (7.10 x 10 <sup>-3</sup> )
30 mm Lead	4.49 x 10 <sup>-2</sup> (3.98 x 10 <sup>-1</sup> )	6.21 x 10 <sup>-2</sup> (5.50 x 10 <sup>-1</sup> )	8.15 x 10 <sup>-4</sup> (7.21 x 10 <sup>-3</sup> )
Parallel Drive Inertia	1:1 Reduction		2:1 Reduction
6 mm Lead (zero stroke)	9.42 x 10 <sup>-2</sup> (8.34 x 10 <sup>-1</sup> )		3.50 x 10 <sup>-2</sup> (3.10 x 10 <sup>-1</sup> )
Add per 25 mm stroke	8.00 x 10 <sup>-4</sup> (7.08 x 10 <sup>-3</sup> )		2.00 x 10 <sup>-4</sup> (1.77 x 10 <sup>-3</sup> )
12 mm Lead (zero stroke)	9.43 x 10 <sup>-2</sup> (8.34 x 10 <sup>-1</sup> )		3.50 x 10 <sup>-2</sup> (3.10 x 10 <sup>-1</sup> )
Add per 25 mm stroke	8.02 x 10 <sup>-4</sup> (7.10 x 10 <sup>-3</sup> )		2.01 x 10 <sup>-4</sup> (1.78 x 10 <sup>-3</sup> )
30 mm Lead (zero stroke)	9.48 x 10 <sup>-2</sup> (8.39 x 10 <sup>-1</sup> )		3.52 x 10 <sup>-2</sup> (3.11 x 10 <sup>-1</sup> )
Add per 25 mm stroke	8.15 x 10 <sup>-4</sup> (7.21 x 10 <sup>-3</sup> )		2.04 x 10 <sup>-4</sup> (1.80 x 10 <sup>-3</sup> )

Standard Motor/Gearbox Mount Codes for the Exlar FTX215

Exlar FTX215 Motor / Gearbox Mounts															
None		Inline				Parallel 1:1					Parallel 2:1				
		Motor Flange Code		Dimension in mm		Motor Flange Code		Dimension in mm			Motor Flange Code		Dimension in mm		
Motor Flange Code	Motor Flange Code	Bolt Circle	Pilot Diam.	Bolt Circle	Pilot Diam.	Motor Flange Code	Bolt Circle	Pilot Diam.	Min. Shaft Length	Motor Flange Code	Bolt Circle	Pilot Diam.	Min. Shaft Length	Motor Flange Code	
NMT- 00	N10- 19	165	130	P10- 19	165	130	74	P20- 19	165	130	55	P20- 23	215	180	65
	N10- 22	215	160	P10- 22	215	160	74	P20- 25	265	230	65	P20- 26	300	250	65
	N10- 23	215	180	P10- 23	215	180	74								
	N10- 24	235	200	P10- 24	235	200	73								
	N10- 25	265	230	P10- 25	265	230	80								
	N10- 26	300	250	P10- 26	300	250	80								
Motor Shaft Code	Motor Shaft Code	Shaft Diam.	Key Width*	Min. Shaft Length	Motor Shaft Code	Shaft Diam.	Key Width*	Motor Shaft Code	Shaft Diam.	Key Width*	Motor Shaft Code	Shaft Diam.	Key Width*	Motor Shaft Code	
00	PA	38	10	80	PA	38	10	PA	38	10	PA	38	10	PA	
	QA	40	12	80	QA	40	12	QA	40	12	QA	40	12	QA	
	RA	42	12	80	RA	42	12	RA	42	12	RA	42	12	RA	
	TA	48	14	80	TA	48	14	TA	48	14	TA	48	14	TA	
	UA	55	16	105	UA	55	16	UA	55	16	UA	55	16	UA	
	VA	60	18	105	VA	60	18	VA	60	18	VA	60	18	VA	
	WA	65	18	105	WA	65	18	WA	65	18	WA	65	18	WA	
Shaft Length	Shaft Diameter Codes	Shaft Length	Shaft Length	Shaft Length	Shaft Length	Shaft Length	Shaft Length	Shaft Length	Shaft Length	Shaft Length	Shaft Length	Shaft Length	Shaft Length	Shaft Length	
000	PA QA RA TA UA VA WA	80-112 80-112 80-112 80-112 105-140 105-140 105-140	073-155	Allowable shaft length range in 1 mm increments	055-155	Allowable shaft length range in 1 mm increments									

\*Key not required for operation

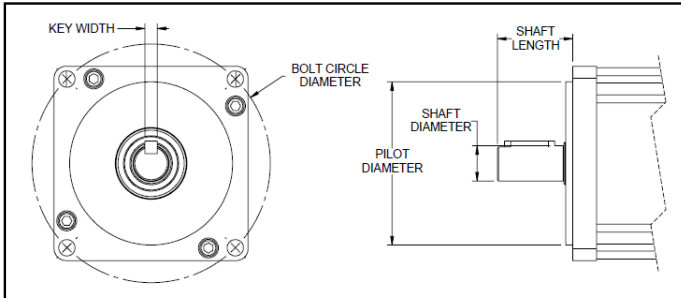

NOTE: Motor/gearbox key not required to interface with Exlar FTX Series actuators

## Performance to Stroke

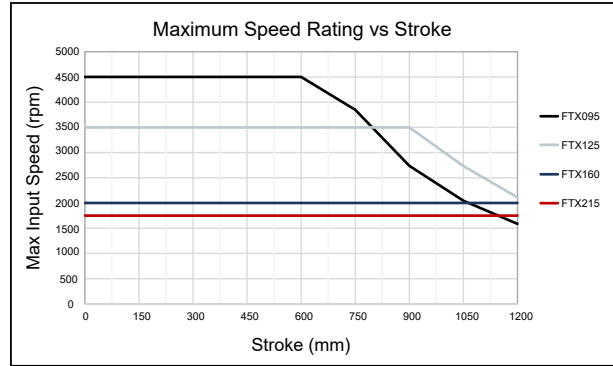
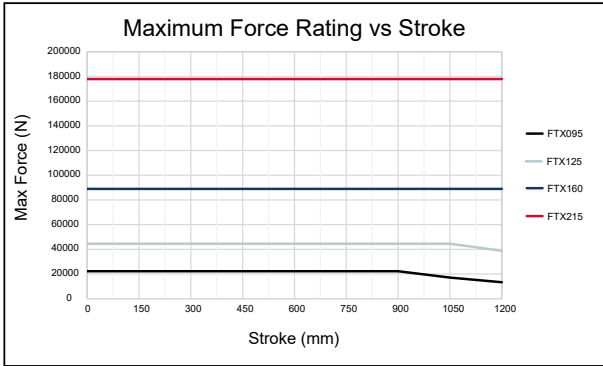

## Estimated Service Life

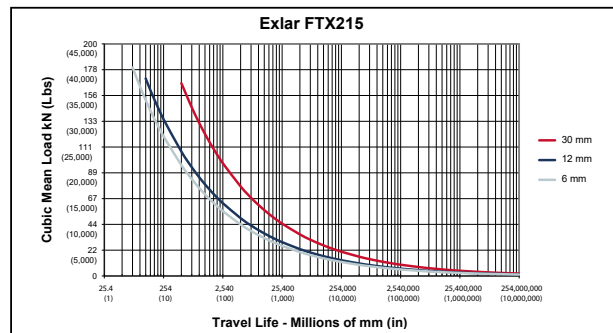
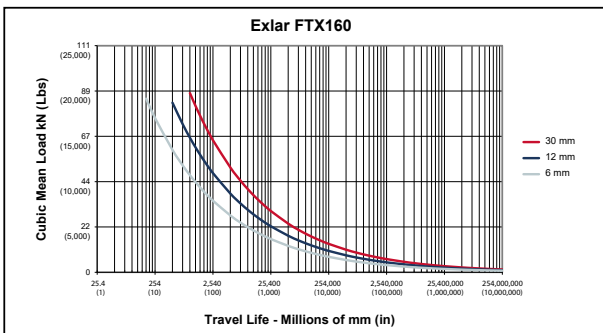
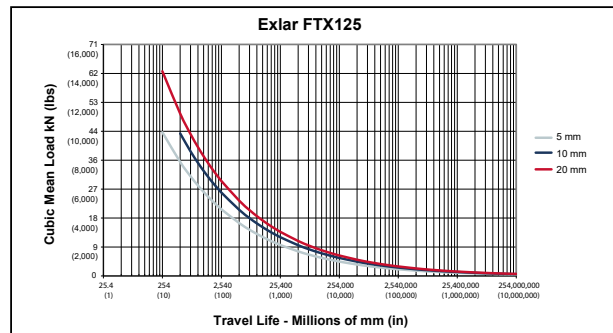
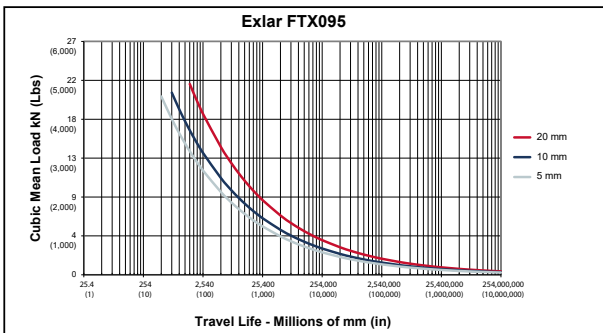

The  $L_{10}$  expected life of a roller screw linear actuator is expressed as the linear travel distance that 90% of properly maintained roller screws manufactured are expected to meet or exceed. This is not a guarantee and these charts should be used for estimation purposes only.

The underlying formula that defines this value is:  
Travel life in millions of inches, where:

$$L_{10} = \left( \frac{C_a}{F_{cml}} \right)^3 \times I$$

$C_a$  = Dynamic load rating (lbf)  
 $F_{cml}$  = Cubic mean applied load (lbf)  
 $I$  = Roller screw lead (inches)

### Service Life Estimate Assumptions:

- Sufficient quality and quantity of lubrication is maintained throughout service life
- Bearing and screw temperature between 20 °C and 40 °C
- No mechanical hard stops (external or internal) or impact loads
- No external side loads
- Does not apply to short stroke, high frequency applications such as fatigue testing or short stroke, high force applications such as pressing.

# Dimensions

## EXLAR FTX095

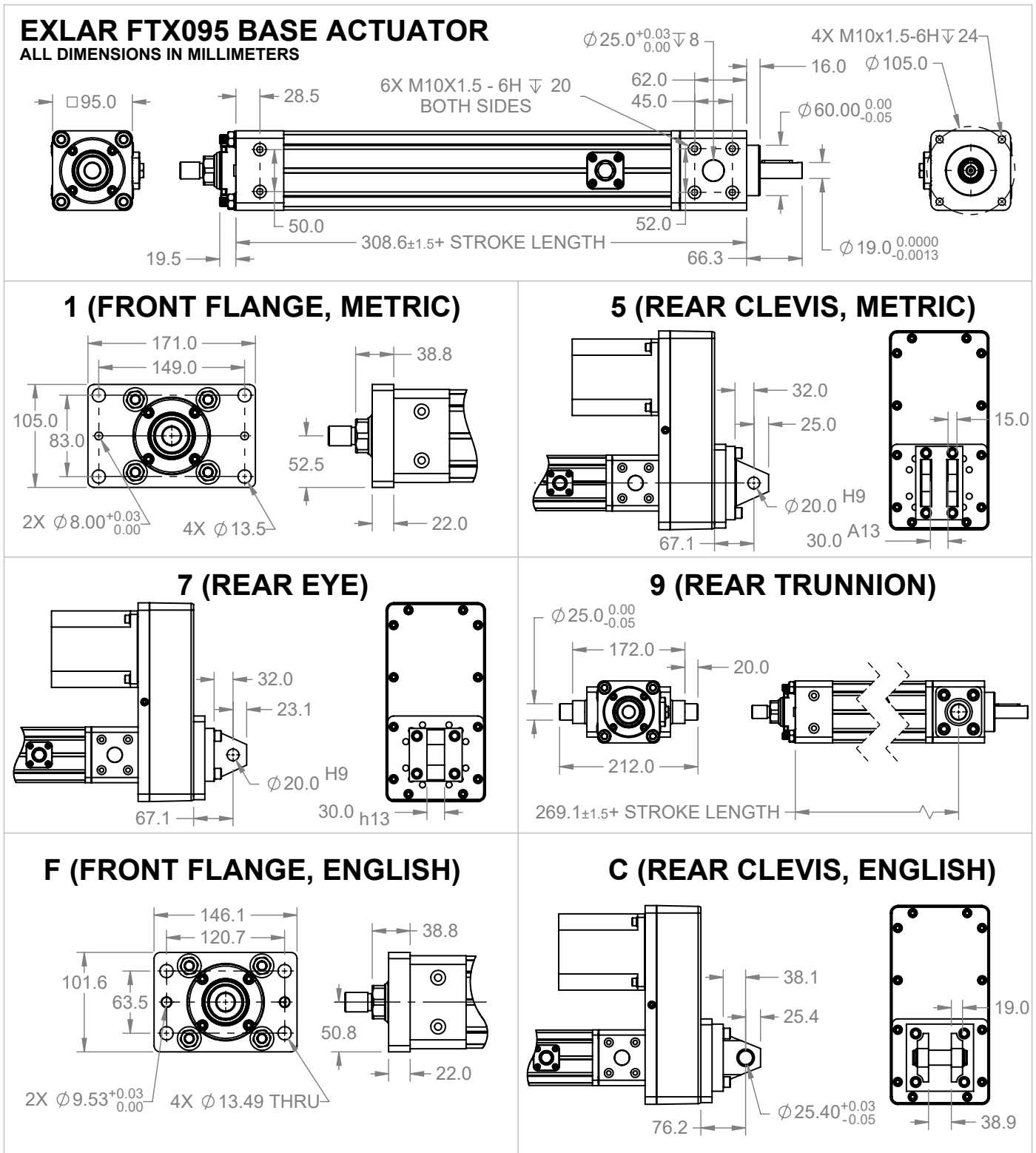

### N10 (INLINE MOUNT)

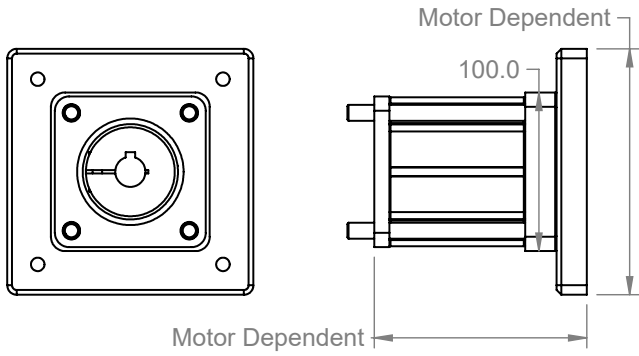

### P10/P20 (PARALLEL MOUNT)

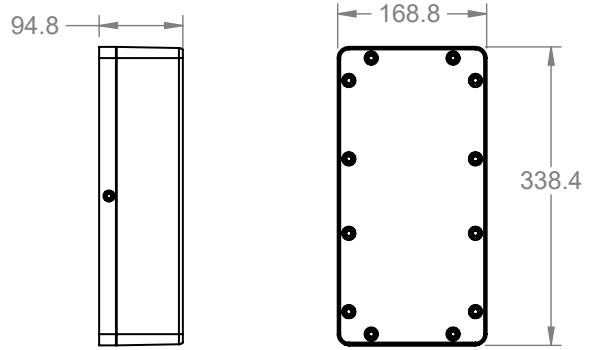

Motor/gearbox key not required to interface with Exlar FTX Series actuators

### ROD ENDS

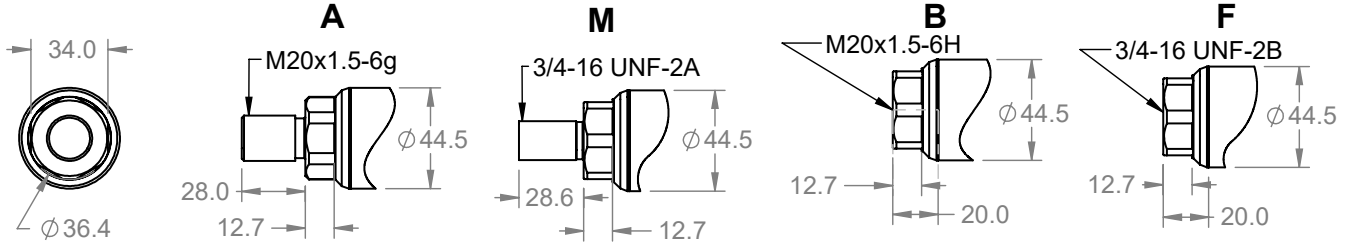

EXLAR FTX125

**EXLAR FTX125 BASE ACTUATOR**  
ALL DIMENSIONS IN MILLIMETERS

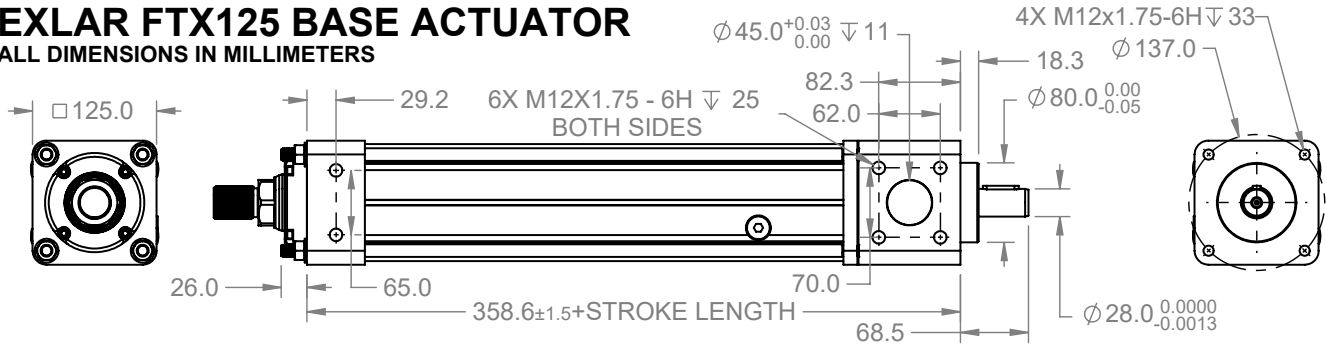

**1 (FRONT FLANGE, METRIC)**

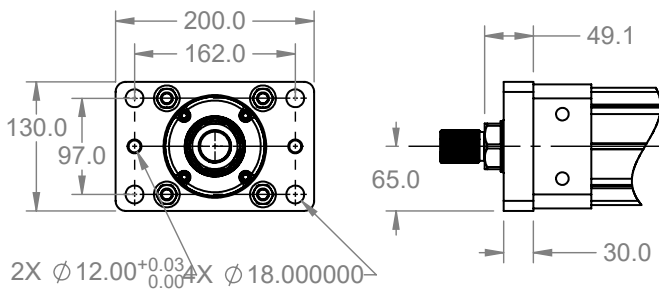

**5 (REAR CLEVIS, METRIC)**

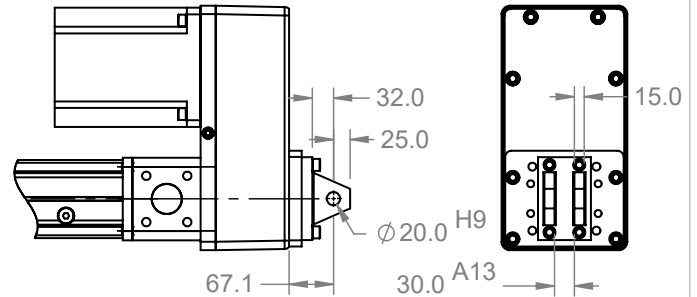

**7 (REAR EYE)**

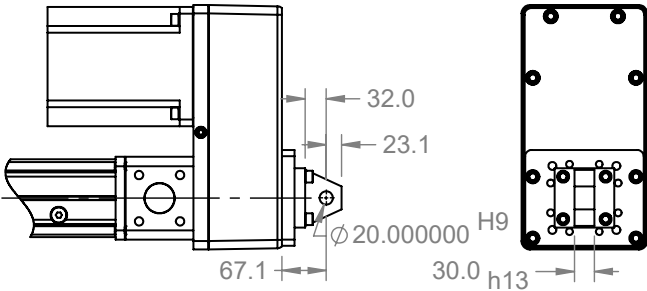

**9 (REAR TRUNNION)**

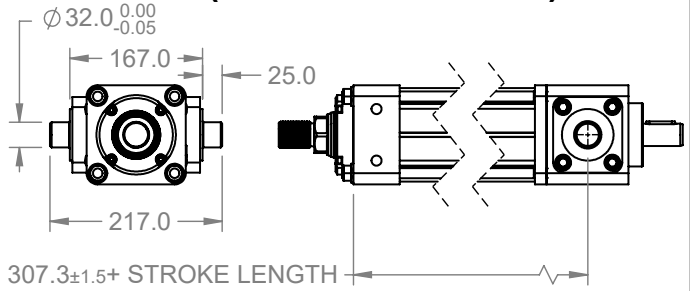

**F (FRONT FLANGE, ENGLISH)**

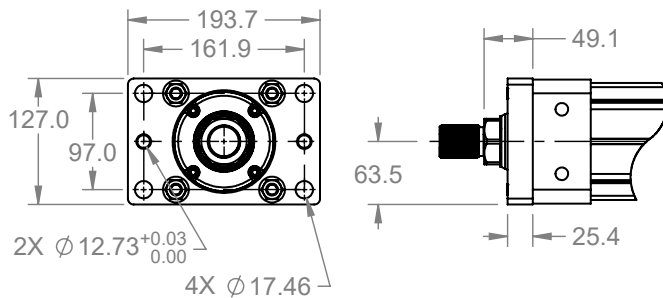

**C (REAR CLEVIS, ENGLISH)**

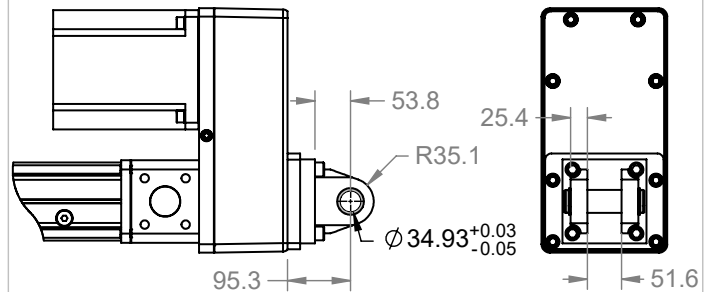

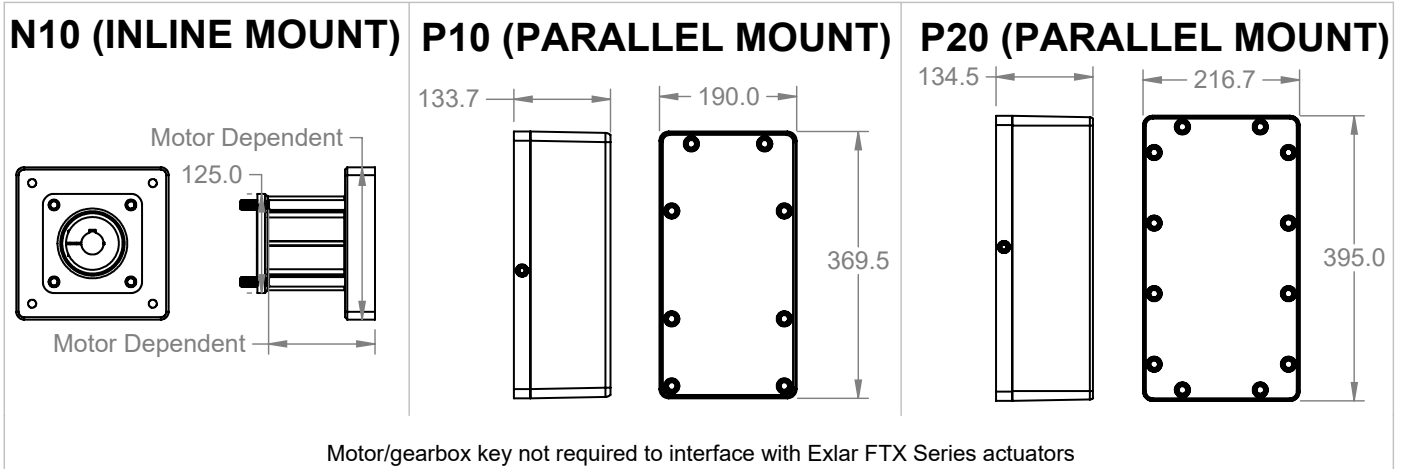

**ROD ENDS**

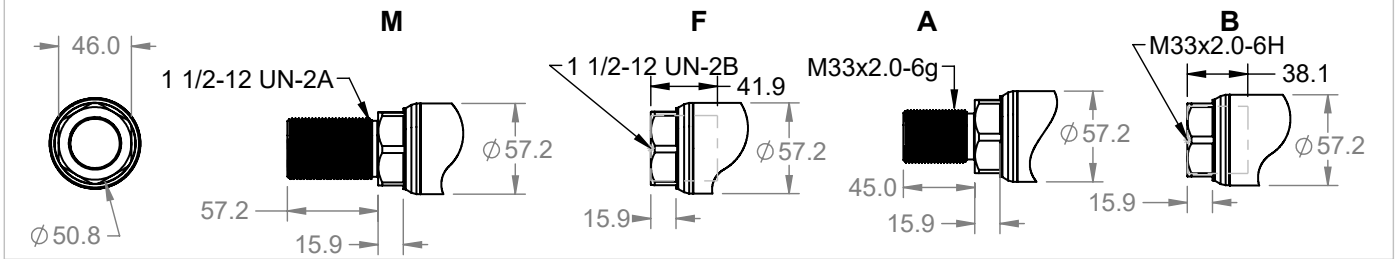

Exlar FTX160

**EXLAR FTX160 BASE ACTUATOR**

ALL DIMENSIONS IN MILLIMETERS

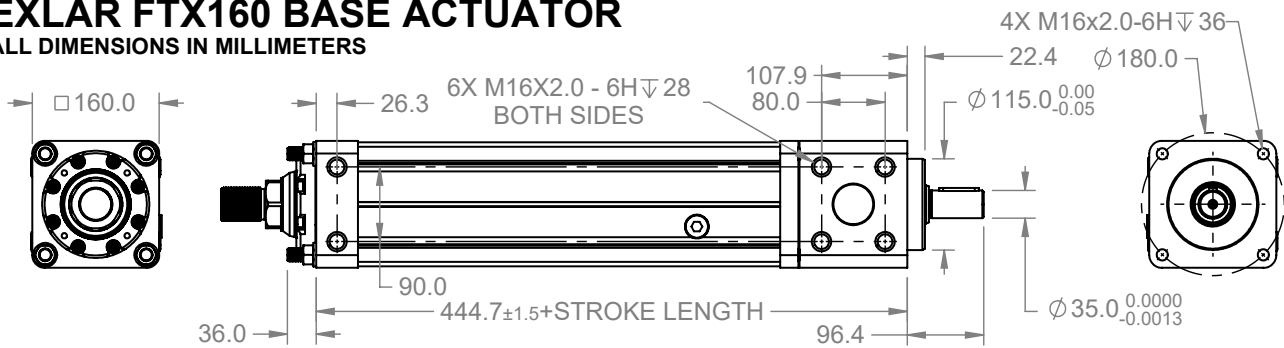

**1 (FRONT FLANGE, METRIC)**

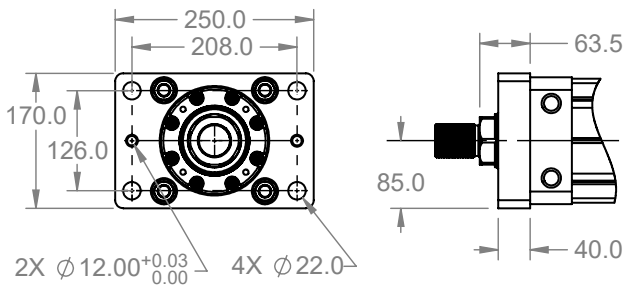

**5 (REAR CLEVIS, METRIC)**

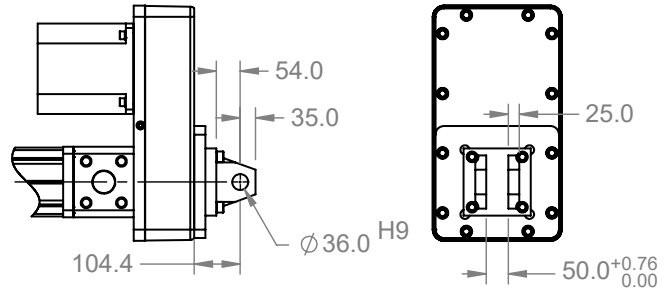

**7 (REAR EYE)**

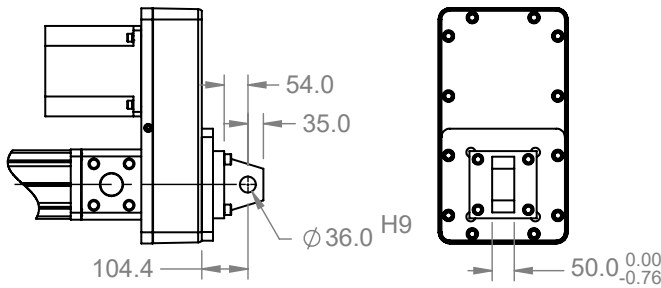

**9 (REAR TRUNNION)**

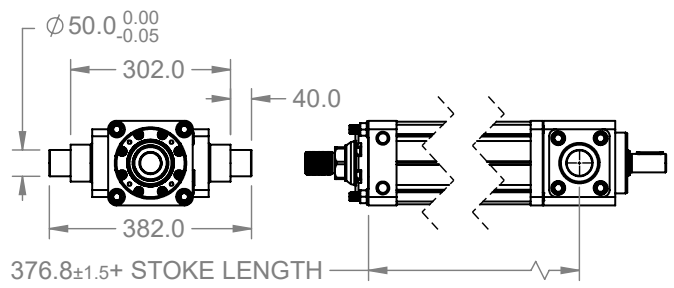

**F (FRONT FLANGE, ENGLISH)**

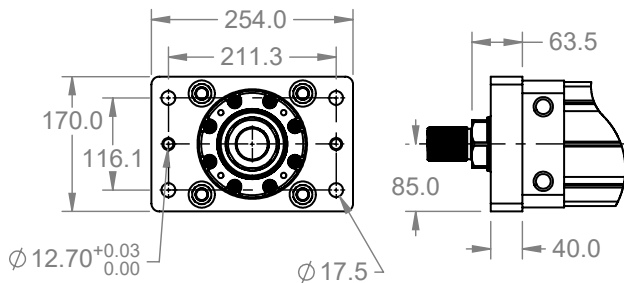

**C (REAR CLEVIS, ENGLISH)**

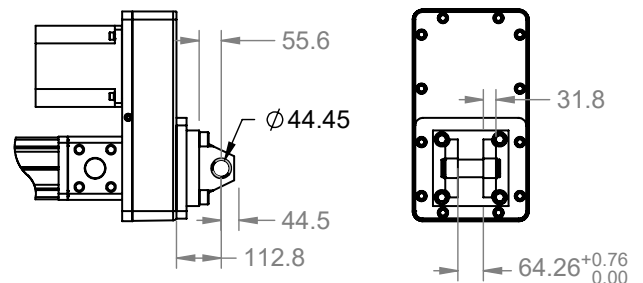

**N10 (INLINE MOUNT)**

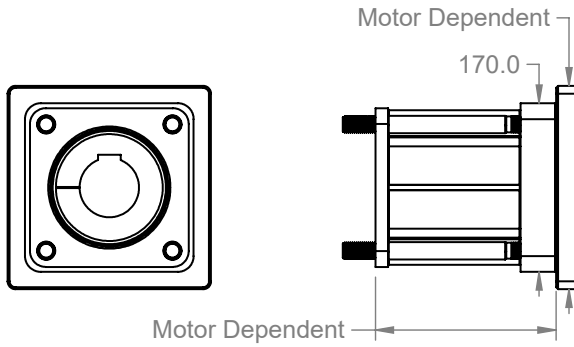

**P10/P20 (PARALLEL MOUNT)**

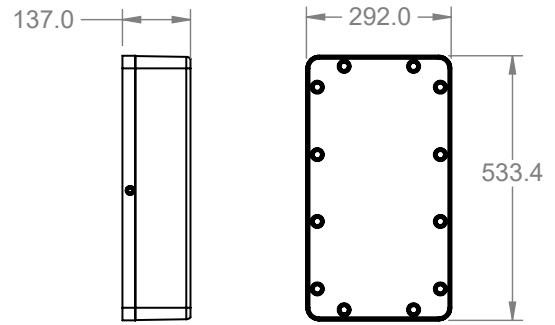

Motor/gearbox key not required to interface with Exlar FTX Series actuators

**ROD ENDS**

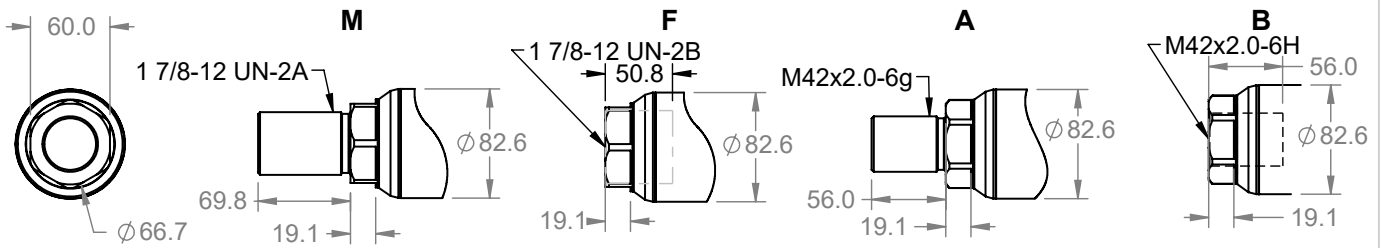

Exlar FTX215

**EXLAR FTX215 BASE ACTUATOR**  $\phi 50.03^{+0.03}_{0.00} \nabla 16$

ALL DIMENSIONS IN MILLIMETERS

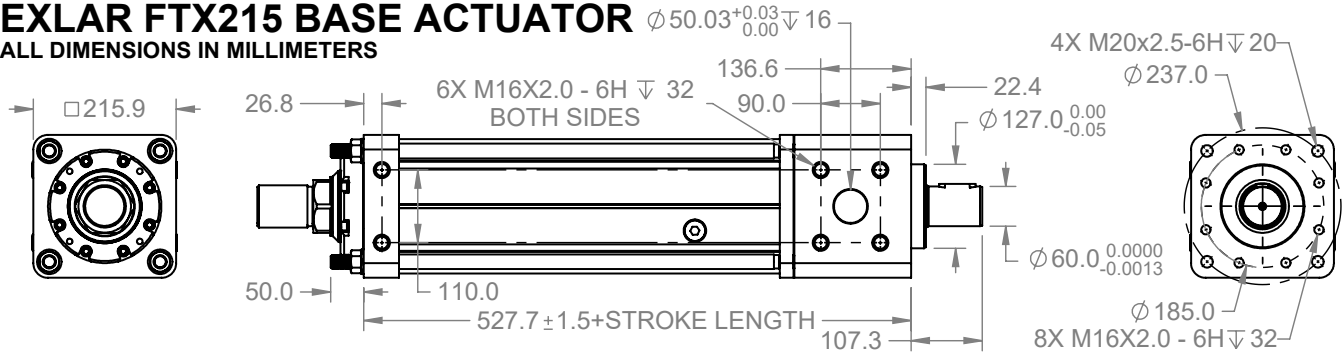

**1 (FRONT FLANGE, METRIC)**

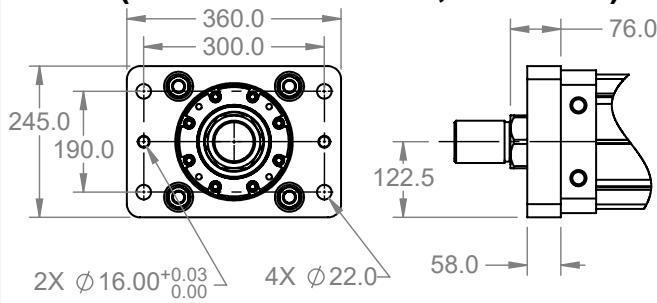

**5 (REAR CLEVIS, METRIC)**

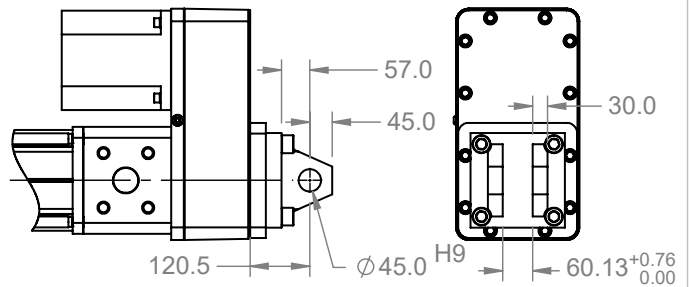

**7 (REAR EYE)**

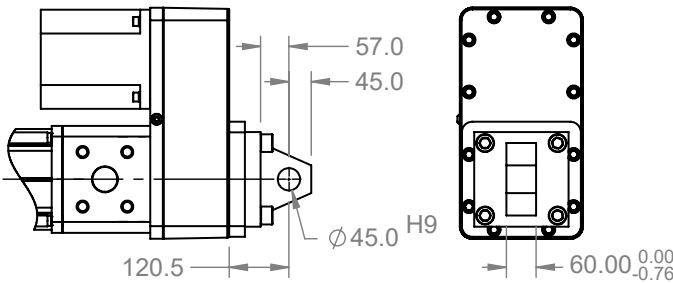

**9 (REAR TRUNNION)**

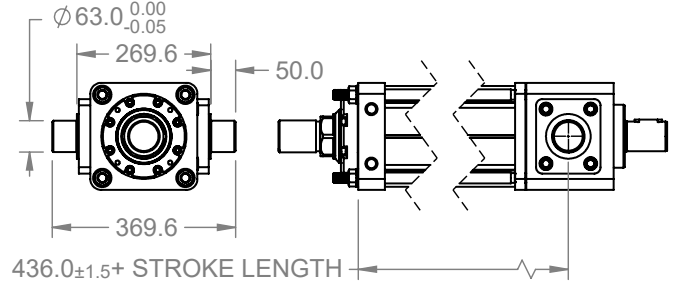

**1 (FRONT FLANGE, ENGLISH)**

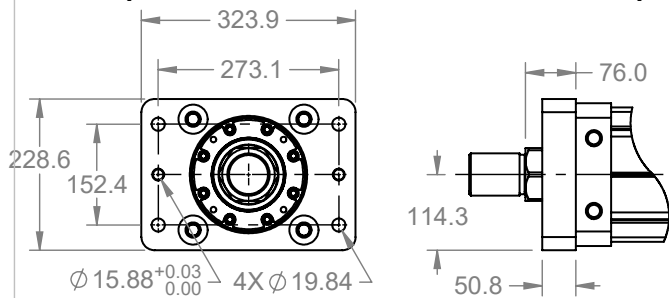

**C (REAR CLEVIS, ENGLISH)**

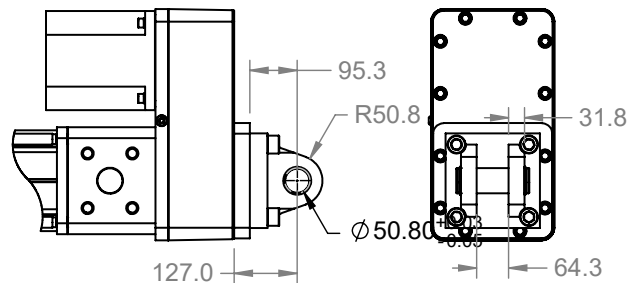

### N10 (INLINE MOUNT)

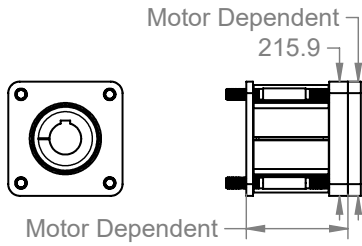

### P10/P20 (PARALLEL MOUNT)

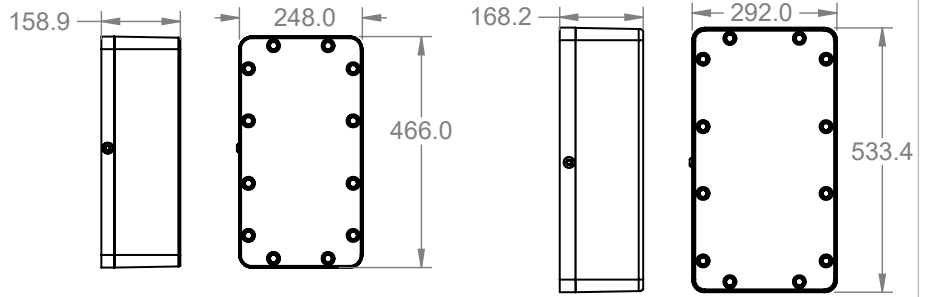

NOTE: 248mm WIDE HOUSING USED FOR MOTORS WITH 215mm MOUNTING B.C AND SMALLER, 1:1 292mm WIDE HOUSING USED FOR ALL 2:1 DRIVE MOTORS

Motor/gearbox key not required to interface with Exlar FTX Series actuators

### ROD ENDS

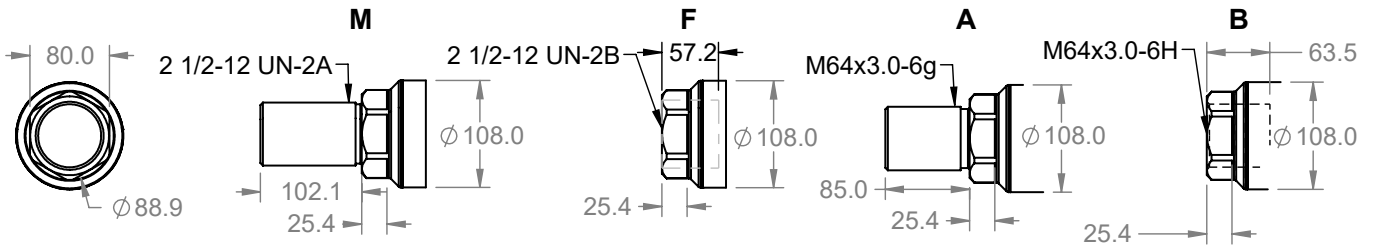

Rod Eye, Spherical

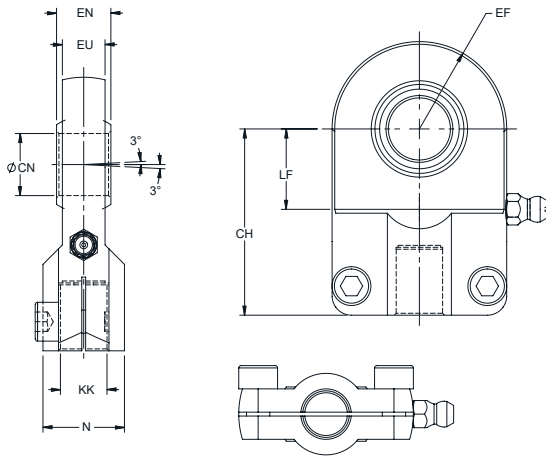

Frame Size		095	125	160	215
AV	mm	29.0	46.0	55.0	86.0
	in	1.14	1.81	2.17	3.39
CH	mm	85.0	130.0	150.0	240.0
	in	3.35	5.12	5.91	9.45
CN	mm	30.0	50.0	60.0	100.0
	in	1.18	1.97	2.36	3.94
EF (max)	mm	41.0	61.0	80.0	120.0
	in	1.61	2.40	3.15	4.72
EN	mm	22.0	35.0	44.0	70.0
	in	0.87	1.38	1.73	2.76
EU (max)	mm	20.0	31.0	39.0	57.0
	in	0.79	1.22	1.54	2.24
KK		M20X1.5 6H	M33X2.0 6H	M42X2.0 6H	M64X3.0 6H
LF (min)	mm	35.0	58.0	68.0	116.0
	in	1.38	2.28	2.68	4.57
N (max)	mm	37.0	57.0	69.0	110.0
	in	1.46	2.24	2.72	4.33

Case Dimensions

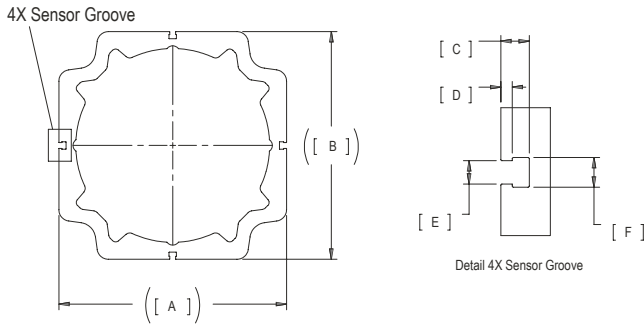

Frame Size		095	125	160	215
A	mm	94	118	156	203
	in	3.7	4.6	6.1	8.0
B	mm	94	118	156	203
	in	3.7	4.6	6.1	8.0
C	mm	4.9	5.6	5.5	6.4
	in	0.19	0.22	0.22	0.25
D	mm	1.1	1.8	1.7	2.5
	in	0.4	0.07	0.07	0.10
E	mm	5.2	5.2	5.3	5.2
	in	0.21	0.21	0.21	0.21
F	mm	6.6	6.6	6.6	6.6
	in	0.26	0.26	0.26	0.26

Rod Clevis

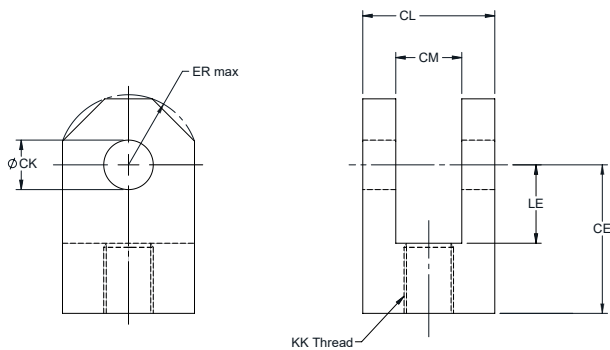

Frame Size		095	125	160	215
CE	mm	60.0	99.0	113.0	168.0
	in	2.36	3.90	4.45	6.61
Ø CK	mm	20.0 h9	36.0 h9	45.0 h9	70.0 h9
	in	0.79	1.42	1.77	2.76
CL	mm	62.0	103.0	123.0	163.0
	in	2.44	4.06	4.84	6.42
CM	mm	30.0	50.0	60.0	80.0
	in	1.18	1.97	2.36	3.15
Ø ER (max)	mm	29.0	50.0	53.0	78.0
	in	1.14	1.97	2.09	3.07
LE (min)	mm	32.0	54.0	57.0	83.0
	in	1.26	2.13	2.24	3.27
KK		M20X1.5 6H	M33X2.0 6H	M42X2.0 6H	M64X3.0 6H

## Exlar FTX Exploded View

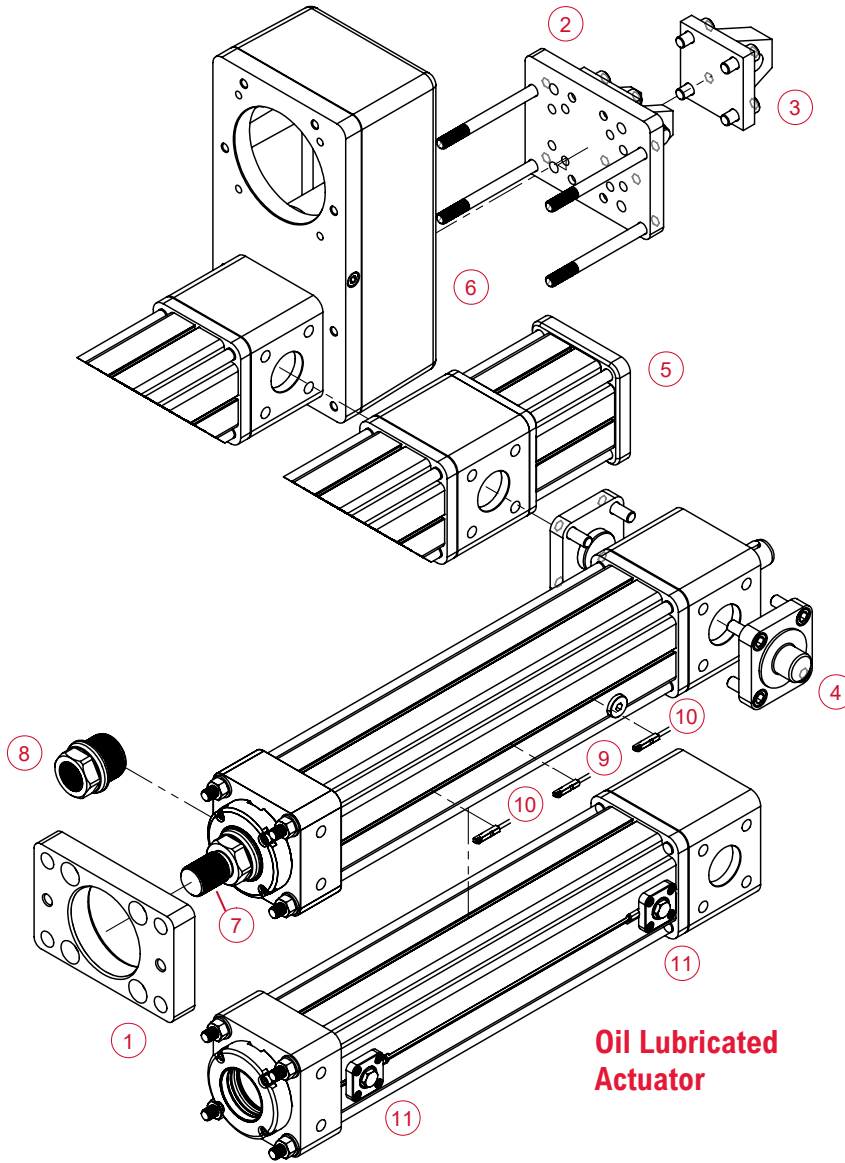

**Grease Lubricated Actuator**

**Oil Lubricated Actuator**

- 1 - Front flange
- 2 - Rear clevis
- 3 - Rear eye
- 4 - Rear trunnion
- 5 - Inline direct drive
- 6 - Parallel, 1:1 belt reduction  
Parallel, 2:1 belt reduction
- 7 - Male, metric thread
- 8 - Female, metric thread
- 9 - External limit switch - N.O., PNP or NPN\*
- 10 - External limit switch - N.C., PNP or NPN\*
- 11 - Oil ports

\*Ordered Separately

## Exlar FTX Actuator Ordering Information

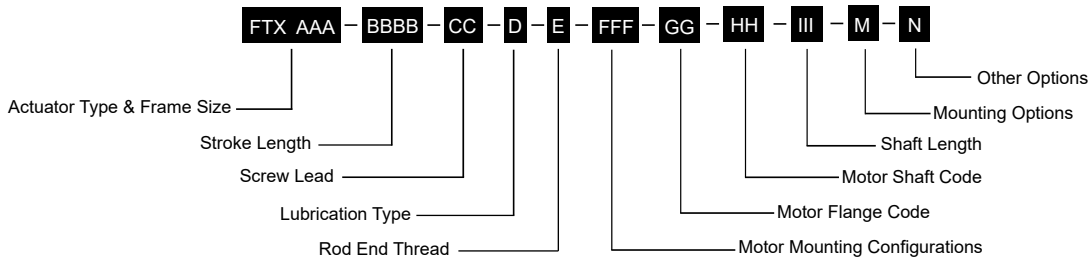

**AAA = Actuator Frame Size**

- 095 = 95 mm
- 125 = 125 mm
- 160 = 160 mm
- 215 = 215 mm

**BBBB = Stroke Length**

- 0150 = 150 mm
- 0300 = 300 mm
- 0600 = 600 mm
- 0900 = 900 mm
- 1200 = 1200 mm

**CC = Screw Lead**

- 05 = 5 mm (FTX095, FTX125)
- 06 = 6 mm (FTX160, FTX215)
- 10 = 10 mm (FTX095, FTX125)
- 12 = 12 mm (FTX160, FTX215)
- 20 = 20 mm (FTX095, FTX125)
- 30 = 30 mm (FTX160, FTX215)

**D = Lubrication Type**

- 1 = Grease
- 2 = Prepared for Oil fill
- 3 = Low Temperature Grease (to -40 °C)

**E = Rod End Thread**

- A = Male, Metric
- B = Female, Metric
- M = Male, English<sup>3</sup>
- F = Female, English<sup>3</sup>

**FFF = Motor Mounting Configurations<sup>1</sup>**

- NMT = None, base unit only
- N10 = Inline, includes shaft coupling
- P10 = Parallel, 1:1 belt reduction
- P20 = Parallel, 2:1 belt reduction

**GG = Motor/Gearbox Flange Code**

See standard motor/gearbox mounting code dimensions

**HH = Motor Shaft Code**

See standard motor/gearbox mounting code dimensions

**III = Shaft Length**

See standard motor/gearbox mounting code dimensions

**M = Mounting Options**

- N = None
- 1 = Front Flange, Metric
- 5 = Rear Clevis, Metric<sup>2</sup>
- 7 = Rear Eye, Metric<sup>2</sup>
- 9 = Rear Trunnion, Metric
- F = Front Flange, English<sup>3</sup>
- C = Rear Clevis, English<sup>3</sup> - FT Equivalent (Not available on Exlar FTX215)
- G = Rear Clevis, Metric<sup>3</sup> - FT Equivalent (Not available on Exlar FTX125 or Exlar FTX215)

**N = Other Options**

- N = None



For Exlar FTX options or specials not listed above, please contact:  
[cha\\_applications@curtisswright.com](mailto:cha_applications@curtisswright.com)

**NOTES:**

1. Always discuss your motor selection with your local sales representative.
2. Not available with inline or NMT motor mount, contact your local sales representative.
3. Available option. May add lead time

## Exlar FTX Accessories

Rod End Attachments	Actuator Option Code	Order Part No.
Rod Clevis, Metric - (Includes jam nut)	N/A	FTXxxx-RC1-KIT
Spherical Rod Eye, Metric - (Includes jam nut)	N/A	FTXxxx-RE1-KIT
Mounting Options		
Front Flange, Metric - (Includes fasteners)	1	FTxxx-ME5-KIT
Rear Clevis, Metric - (Includes fasteners & pin)	5	FTXxxx-MP1-KIT
Rear Clevis, Metric (Clevis Only)	N/A	71674
Clevis Pin, Metric (Req'd w/ 71674) - (Includes retaining rings)	N/A	74472
Rear Eye, Metric - (Includes fasteners)	7	FTXxxx-MP3-KIT
Rear Eye, Metric (Eye Only)	N/A	71675
Rear Trunnion, Metric - (Includes fasteners)	9	FTXxxx-MT2-KIT
Front Flange, English (FT Equivalent) - (Includes fasteners)	F	FTXxxx-FTF-KIT
Rear Clevis, English (FTEquivalent) - (Includes fasteners & pin)	C	FTXxxx-FTC-KIT
Rear Clevis, Metric (FT Equivalent) - (Includes fasteners & pin)	G	FTXxxx-FTG-KIT
Limit Switches		
Normally Open PNP Limit Switch (10-30 Vdc, 1 m. 3 wire embedded cable)	N/A	43403
Normally Closed PNP Limit Switch (10-30 Vdc, 1 m. 3 wire embedded cable)	N/A	43404
Normally Open NPN Limit Switch (10-30 Vdc, 1 m. 3 wire embedded cable)	N/A	67634
Normally Closed NPN Limit Switch (10-30 Vdc, 1 m. 3 wire embedded cable)	N/A	67635
Replacement Parts		
Front Seal Bushing Assembly - (Includes fasteners)	N/A	FTXxxx-FSB-KIT

## Warranty and Limitations of Liability

Please see our warranty on our website here: <https://www.cw-actuation.com/en-gb/about/terms-conditions> for details.



**SENSORS & ACTUATION**

18400 W. 77th Street  
Chanhassen, MN 55317

T: (+1) 952.500.6200

E: [cha\\_applications@curtisswright.com](mailto:cha_applications@curtisswright.com)

W: [actuation.curtisswright.com](http://actuation.curtisswright.com)