

Exlar® Tritex® EVA Specifications

The Tritex EVA intelligent electric valve actuators were designed specifically for valve control in the process and oil & gas industries. Zero emissions, low maintenance, and proven reliability make this product perfect for companies needing to eliminate their methane emissions and improve operational efficiency.

Benefits

- 100% duty cycle rated for continuous modulation
- Fast valve close times in as little as 1 second
- Robust roller screw drive train for low maintenance and industry leading life
- Servo design allows for valve jam protection
- Advanced valve seating control extends valve life
- Absolute position sensing for increased control
- Compact overall footprint

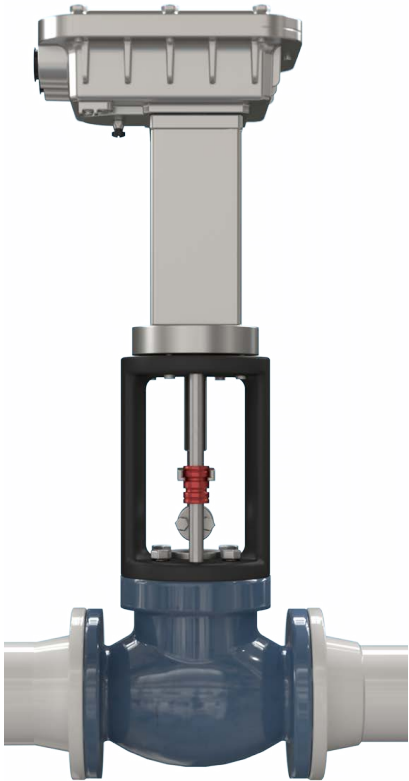

Power & Control	
Rated Thrust	1000 lbf (4.4 kN)
Seating Thrust ISO Rated Thrust	1500 lbf (6.67 kN)
Rated Speed	1 in/s (24.4 mm/s) @ 24 Vdc
Stroke Length	4 in (101.6 mm)
Input Voltage	12-24 Vdc nominal, 9-32 Vdc max range
Input Current	10 A @ rated thrust, 1 A @ nominal thrust
Endurance & Life	
Endurance	10,000 + starts, 3600+ starts per hour
Duty	Class D continuous modulating, 100% duty cycle
Life	10,000,000+ cycles over 10 years
Communication & Commissioning	
Serial Interface	Isolated Modbus RTU (RS-485), max baud rate 38.4 k
Software Tool	Free-to-download Expert PC commissioning tool
Inputs & Outputs	
Digital Inputs	3 - Isolated, 9-30 Vdc
Digital Outputs	2 - Isolated, 9-30 Vdc
Analog Input	1 - Isolated, 4-20 mA, position / thrust demand 0.1% resolution 0.5% linearity over temperature range
Analog Output	1- Isolated, 4-20 mA, position / thrust feedback 0.1% resolution, 0.5% linearity over temperature range

Environmental & Mounting	
Enclosure	NEMA 4X, IP66
Operating temperature	-40 to 149 °F (-40 to 65 °C)
Ambient storage temperature	-58 to 185 °F (-50 to 85 °C)
Mounting	Face mount, any orientation, with valve adapter
Noise	Less than 70 dB operation
Weight	Approximately 17.2 lbs (7.8 kg)
Standards	
Approvals	cCSAus Class 1, Division 2, Group A, B, C, D, T5, CE
Product Standards	ISO 22153, RoHS

Dimensions

Tritex EVA080

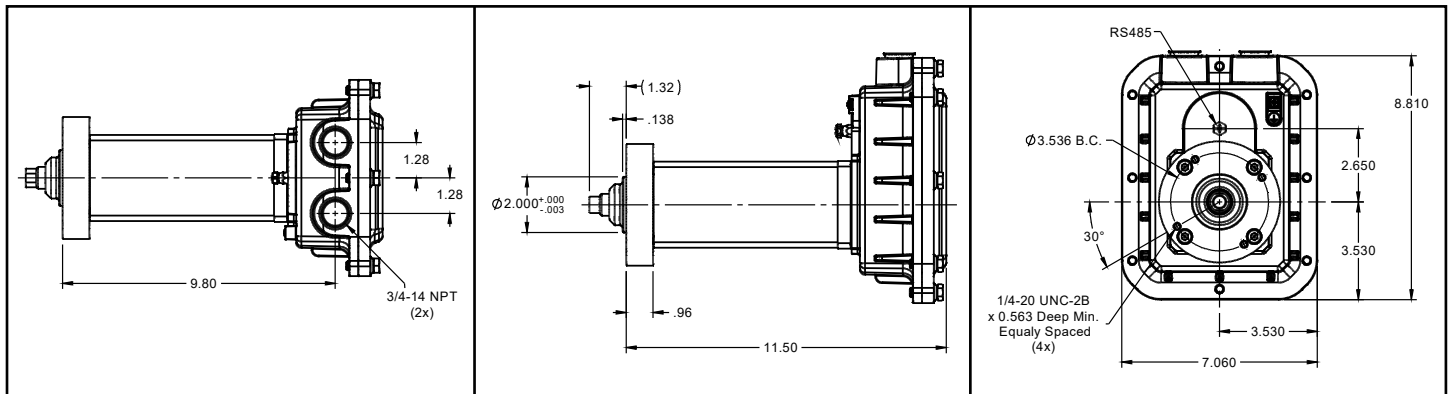

Ordering Info

Sample Product Number: EVA080-100-01-B-AA-A-R-XXXX

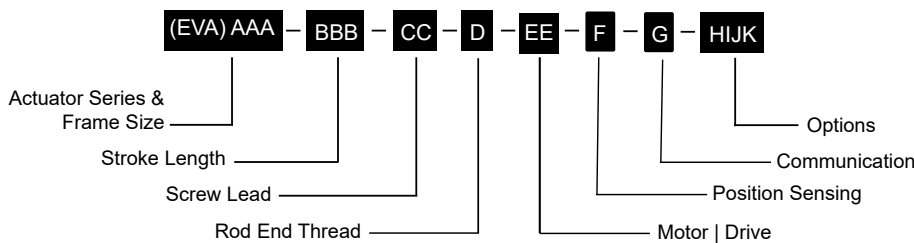

Actuator Series

EVA = Electric Valve Actuator, Linear

AAA = Actuator Frame Size

080 = 80 mm (3.1 in)

BBB = Stroke Length

100 = 100 mm (4 in)

CC = Screw Lead

01 = 2.54 mm (0.1 in), Roller Screw

D = Rod End Thread

B = Female Metric, M12x1.25

EE = Motor | Drive

AA = Standard Motor (A), Standard Servo Drive (A), 12-24 Vdc Input

F = Position Sensing

H = Absolute Position Sensing

G = Communication

R = Standard Modbus RTU (RS-485)

Go to www.exlar.com
to download resources.

